

No.S-2/ CMTS/TENDER-II/2013-2014



Bharat Sanchar Nigam Ltd.

2nd Floor, Telephone Exchange Building
BJB Nagar, Bhubaneswar-14

TENDER DOCUMENT

ERECTION OF 40M NBFL GBT & IT'S ASSOCIATED WORKS IN ODISHA FOR GSM MOBILE PROJECT

Period of issue of tender paper: 11:00 Hrs. to 16:00 Hrs on all working days
From **23rd OCT.' 2013 to 11th NOV.' 2013**

Dropping of Tender Documents : Up to 13:00 Hrs of **12th NOV.' 2013**
Date & time of opening of Tender : **16:00 Hrs of 12th NOV.' 2013**

SDE.(Estimate)
O/o the G.M.(CMTS), BSNL
Odisha Telecommunications Circle
Bhubaneswar.

PLEASE VISIT US AT
www.orissa.bsnl.co.in

Cost of Tender Paper: Rs.525/-

CONTENT

SECTION	TOPIC	PAGE NO.
SECTION-I	NOTICE INVITING TENDER	03
SECTION-II	INSTRUCTION TO BIDDERS	04-13
	A INTRODUCTION	
	B THE BID DOCUMENT	
	C PREPARATION OF BIDS	
	D SUBMISSION OF BIDS	
	E BID OPENING & EVALUATION	
	F AWARD OF CONTRACT	
SECTION-III	CONDITION OF CONTRACT	14-26
SECTION-IV	CONSTRUCTION, SPECIFICATION & JOB DESCRIPTION	27-31
SECTION-V	BID FORM	32
SECTION-VI	TECHNICAL BID	33
SECTION-VII	FINANCIAL BID (RATE SHEET)	34
SECTION-VIII	UNDERTAKING & DECLARATION	35
SECTION-IX	PERFORMANCE SECURITY GUARANTEE (BOND FORM)	36
SECTION-X	LETTER OF AUTHORISATION TO ATTEND BID OPENING	37
SECTION-XI	BID SECURITY FORM	38
SECTION-XII	PROFORMA FOR NO NEAR RELATIVE(S) CERTIFICATE	39
SECTION-XIII	INFORMATION ABOUT TENDERER	40
SECTION-XIV	FORMAT FOR AGREEMENT	41

SIGNATURE OF THE TENDERER WITH SEAL

SECTION-I

(A Govt. Of India Enterprise)

O/o G.M.(CMTS), Odishaa Telecom Circle
2nd Floor, BJB Nagar Telephone Exchange, BBSR-14**No. S-2/ CMTS/TENDER-II/2013-2014****Dated at Bhubaneswar the 22nd Oct. 2013****NOTICE INVITING TENDER**

Sealed tenders (Packing PVC Tape/Sealing Wax) are invited for and on behalf of BSNL by General Manager (CMTS) Bhubaneswar from bonafide and experienced contractors for carrying out Erection of 40M NBFL GBT & its Associated Works in Odisha for GSM Mobile Project.

01	Name of the work	ERECTION OF 40M NBFL GBT & IT'S ASSOCIATED WORKS IN ODISHA FOR GSM MOBILE PROJECT
02	Tender papers can be had from	The SDE (EST), O/O G.M. (CMTS), Bhubaneswar or can be downloaded from our website: www.orissa.bsnl.co.in
03	Cost of Tender paper	Rs.525/- (Rupees Five hundred twentyfive) only (Non-refundable)
04	Tentative cost of work	Rs.26,00,000.00 (Rupees Twentysix lakh) only
05	Mode of Payment	A/c payee DD/BC drawn on any Scheduled/Nationalized Bank Payable at Bhubaneswar in favour of Accounts Officer (Cash), O/o GM. (CMTS), Bhubaneswar, should be drawn after the date of publication of NIT.
06	Eligibility of Bidders	Valid contractor license PAN card Income Tax return for the financial year 2011-12 Valid Labour License. Valid EPF registration Certificate with proof of up to date payment. Valid Workman's compensation insurance or ESI certificate Valid Service tax registration certificate with proof of up to date payment. Experience certificate of successfully completed 40M and above height telecom tower erection & associated works in BSNL / MTNL/TCIL/ITI/Central Govt./Central PSU/State Govt./State PSU in last three financial years worth Rs.9,00,000/- or more issued by an officer not below the equivalent rank of TDM/ DGM/SE of BSNL. Cost of Tender paper Rs.525/-
07	Sale of tender documents	On all working day, between 1100 hrs to 1600hrs up to 11.11.2013 .
08	Dropping of tender paper	Can be dropped in Tender Box available at SDE (Genl.) room or sent by Regd. Post up-to 13:00hrs of 12.11.2013 , so as to reach before time.
09	Opening of Tender	The tender will be opened at 16:00 Hrs. of 12.11.2013 in the chamber of AGM (NWP-II), 2nd floor, Telephone Exchange Building, BJB Nagar, BBSR-14
10	Rejection of Tender	Incomplete tender, ambiguous and Conditional rate, unsealed, late receipt will be rejected.

NB: Cost of Tender Paper is inclusive of VAT @ 5%.

The undersigned reserves the right to cancel/reject any or all tenders without assigning any reason thereof or is not bound to accept the lowest tender.

**GENERAL MANAGER (CMTS)
FOR BHARAT SANCHAR NIGAM LTD.**

SIGNATURE OF THE TENDERER WITH SEAL

SECTION II**INSTRUCTIONS TO BIDDERS****A. INTRODUCTION****1. DEFINITIONS:**

- (a) **“The Tendering authority”** means **GENERAL MANAGER (CMTS), ODISHAA TELECOM CIRCLE, BHUBANESWAR.**
- (b) **“The Bidder”** means the individual or firm who participates in this tender and submits its Bid.
- (c) **“The contractor”** means the individual or firm executing the work order under the Contract.
- (d) **“The Work Order”** means the order placed by the Tendering authority including all attachments and appendices thereto and all documents incorporated by reference therein on the contractor. The work order shall be deemed as “Contract” appearing in the document.
- (e) **“The Contract Price”** means the price payable to the contractor under the work order for the full and proper performance of its contractual obligations.
- (f) **“Acceptance testing”** is a process of testing of the works as per the specifications including requirement for use in BSNL network. Acceptance testing is carried out in simulated field environment and includes stability, reliability and environmental tests.
- (g) **“Telecom tower erection & associated works”** means erection of telecom tower, painting of telecom tower, provisioning and fixing lightening arrestor, supply & fixing of aviation lamp and provision of ring earth including transportation of telecom towers and supply & fitting of horizontal and vertical wave guide.

2. ELIGIBLE BIDDERS:

- i) The bidder should have valid contractor license.
- ii) The bidder should have PAN Card. In case of proprietor ship PAN should be in the Individual's name and in case of firm/partnership the PAN in firm's name and should have Income Tax return for the financial year 2011-12.
- iii) The bidder should have Valid Labour License.
- iv) The bidder should have Valid EPF registration Certificate with proof of up to date payment
- v) The bidder should have Valid Workman's compensation insurance or ESI certificate with up to date payment.
- vi) The bidder should have Valid Service tax registration certificate with proof of up to date payment.
- vii) The bidder should have Experience certificate of successfully completed 40M and above height telecom tower erection & associated works in BSNL / MTNL/TCIL/ITI/Central Govt./Central PSU/State Govt./State PSU in last three financial years worth **Rs.9,00,000/-** or more issued by an officer not below the equivalent rank of TDM/ DGM/SE of BSNL.
- viii) The bidder should have Cost of Tender Paper worth Rs.525.00(Rupees One five hundreds twentyfive)only & **EMD for Rs.52,000.00** (Rupees fifty two thousand thousand) only deposited in favour of Accounts Officer (Cash), O/o G.M. (CMTS), Bhubaneswar in shape of DD / BC payable at Bhubaneswar from any Scheduled/Nationalized Bank.
- ix) The bidder should submit an undertaking to the effect that none of their relatives are working in BSNL as per the format in Section-XII.

SIGNATURE OF THE TENDERER WITH SEAL

- x) The bidder should have authenticated partnership deed, in case of partnership firm and power of attorney to the representative of the firm to operate the tender.
- xi) Original "Power of Attorney" in case of person other than the tenderer has signed the tender document.

3. **COST OF BIDDING:**

The bidder shall bear all costs associated with the preparation and submission of the bid. The tendering authority will in no case be responsible or liable for these costs, regardless of the conduct or outcome of the bidding process.

B. **THE BID DOCUMENTS:**

4. **BID DOCUMENTS:**

4.1 The works required, bidding procedures and contract terms are prescribed in the bid documents. The bid documents include:

- a) Notice Inviting Tender.
- b) Instruction to Bidders.
- c) Conditions of the Contract.
- d) Construction, Specification and Job description.
- e) Bid form.
- f) Price schedule.
- g) Undertaking and declaration.
- h) Performance Security Bond Form.
- i) Letter of authorization to attend Bid opening.
- j) Undertaking in respect of non-working of relatives in BSNL.
- k) Information about Tenderers.

4.2 The bidder is expected to examine all instructions, forms, terms and specifications in the bid documents. **Failure to furnish all information required as per the bid documents or submission of bids not substantially responsive to the bid documents in every respect will be at the bidder's risk and shall result in rejection of the bid.**

5 **CLARIFICATION OF BID DOCUMENTS:**

5.1 A prospective bidder, requiring any clarification of the bid documents shall notify the tendering authority in writing or by telex or FAX at the tendering authority's mailing address indicated in the invitation for bids. The tendering authority shall respond in writing to any request for clarification of the bid documents, which it receives **not later than 5(Five) days prior to the last date for the submission of bids**. Copies of the query (without identifying the source) and clarifications by the tendering authority shall be sent individually to all the prospective bidders who have received the bid documents.

5.2 Any clarification issued by BSNL in response to query raised by prospective bidders shall form an integral part of bid documents and it may amount an amendment of relevant clauses of the bid document.

5.3 The correction/modification, if any, in the tender document will be uploaded in the website i.e. www.orissa.bsnl.co.in up to **23.00hrs** of **08.11.2013** which will be treated as final.

6 AMENDMENT OF BID DOCUMENTS:

- 6.1 At any time, prior to the date for submission of bids, the tendering authority may, for any reason whether at its own initiative or in response to a clarification requested by a prospective Bidder, modify the bid documents by amendments.
- 6.2 The amendments shall be notified in writing or by telex or FAX to all prospective bidders on the address intimated at the time of purchase of bid document from the tendering authority and these amendments will be binding on them.
- 6.3 In order to afford prospective bidders reasonable time to take the amendments into account in preparing their bids, the Tendering authority may, at its discretion, extend the deadline for the submission of bids suitably.

C. PREPARATION OF BIDS:**7. DOCUMENTS COMPRISING THE BID:**

It is a two-bid system and the bid prepared by the bidder shall comprise the following components:

- i) **TECHNICAL BID:** Technical bid shall comprise the following components:
- a) Documentary evidence established in accordance with Clause 2 and 10 of Section-II that the bidder is eligible to bid and is qualified to perform the contract if his bid is accepted.
 - b) Bid form (**Section-V**) completed in accordance with Clause 8 of Section-II.
 - c) Bid Security furnished in accordance with Clause 11.
- ii) **FINANCIAL BID:** Financial bid shall comprise the completed “**PRICE SCHEDULE**” (**Section-VII**) in accordance with Clause-9.

8. BID FORM:

The bidder shall complete the Bid Form and the appropriate Price schedule furnished in the Bid Documents, indicating the works to be done, a brief description of the works and prices are as per **Section-IV & VII** respectively.

9. BID PRICES:

- 9.1 The bidder shall give the total composite price inclusive of all levies & taxes i.e. Sales Tax and Excise, packing, forwarding, freight and insurance charges etc. but exclusive of **Service Tax if any**. Service Tax, if any, should be shown separately, shall be paid as applicable. The basic unit price and other component price need to be individually indicated against the works under the contract as per price schedule given in **Section VII**. The offer shall be firm in Indian Rupees. **Bidders shall have to quote price(s) against all the items, for tenders where numbers of items are more than one.**
- 9.2 The prices quoted by the bidder shall remain fixed during the entire period of contract and shall not be subject to variation on any account. A bid submitted with an adjustable price quotation will be treated as non-responsive and rejected.
- 9.3 In case of any discrepancies of quoting rate in figures and words, the rate quoted in words will be considered.
- 9.4 Erasures/corrections of price bid will not be entertained.
- 10. DOCUMENTS TO BE SUBMITTED ALONGWITH TENDER DOCUMENT:**
- 10.1 The bidder shall furnish as part of its bid documents establishing the bidder's eligibility, the following documents:
- i) Attested Xerox copy of valid contractor license.

- ii) Attested Xerox copy of PAN Card & Income Tax return for the F/Y 2011-12. In case of proprietorship PAN should be in the Individual's name and in case of firm/partnership the PAN in firm's name.
- iii) Attested Xerox copy of Valid Labour License.
- iv) Attested Xerox copy of Valid EPF registration Certificate with proof of up to date payment
- v) Attested Xerox copy of Valid Workman's compensation insurance or ESI certificate with up to date payment.
- vi) Attested Xerox copy of Valid Service tax registration certificate with proof of up to date payment.
- xii) Attested Xerox copy of Experience certificate of successfully completed 40M and above height telecom tower erection & associated works in BSNL / MTNL/TCIL/ITI/Central Govt./Central PSU/State Govt./State PSU in last three financial years worth **Rs.9,00,000/-** or more issued by an officer not below the equivalent rank of TDM/ DGM/SE of BSNL.
- vii) The Cost of Tender Paper worth Rs.525.00 & **EMD for Rs.52,000.00** in favour of Accounts Officer(Cash), O/o G.M. (CMTS), Bhubaneswar in shape of DD / BC payable at Bhubaneswar.
- viii) The bidder should submit an undertaking to the effect that none of their relatives are working in BSNL as per the format in Section-XII.
- ix) Attested Xerox copy of authenticated partnership deed, in case of partnership firm and power of attorney to the representative of the firm to operate the tender.
- x) Original "Power of Attorney" in case of person other than the tenderer has signed the tender document.
- xi) Tender document should be signed by the bidder on all pages with seal. All documents should be attested with date by a Gazetted officer/Notary Public and also should be signed by the bidder putting "submitted by me".

Note: If any one of the above items required to be submitted along with the technical bid is found wanting, the offer is liable to be rejected at that stage. However, the tendering authority at its discretion may call for any clarification regarding the bid documents within a stipulated time period. In case of non compliance of such queries, the bid will out rightly rejected without entertaining further correspondence in this regard. The bidder is responsible for authenticity of the document.

10.2 All pages of the original Bid submitted in with Technical bid including blank pages with scoring except for un-amended printed literature shall be signed by the person or persons signing the Bid.

10.3 The copy of certificates issued by the competent authority duly attested by a Gazetted Officer / Notary Public.

10.4 Original documents to be produced for verification before award of contract.

11. BID SECURITY:

11.1

- i) EMD of **Rs.52, 000.00** should be submitted in the form of an account payee Bank Draft/Banker's Cheque drawn on any Scheduled/Nationalized Bank payable at Bhubaneswar and in favour of Accounts Officer (Cash), O/o GM (CMTS), Bhubaneswar along with the tender document. The EMD is required to protect the company against the risk of bidder's conduct, which would warrant the security forfeiture.
- ii) A bid not secured as above shall be rejected by the accepting authority as non-responsive.
- iii) The successful bidder's D.D for EMD will be discharged upon the bidders acceptance of the LOI and furnishing B.G. 5% of value of awarded work with validity up to one and half year on request.

SIGNATURE OF THE TENDERER WITH SEAL

- iv) The EMD of the unsuccessful bidders will be discharged/returned as promptly as possible as but not later than 30 days after expiry of the period of bid validity.
 - v) The EMD may be forfeited if bidder withdraws his bid during the period of bid validity fails, to sign the contract and furnish performance security.
 - vi) In case of (v) above, the bidder will not be eligible to participate in the tender for same work for one year from the date of acceptance of LOI. The bidder will not approach the court against the decision of G.M. (CMTS), Bhubaneswar in this regard.
- 11.2 The bid security is required to protect the tendering authority against the risk of bidder's conduct, which would warrant the security's forfeiture pursuant to clause 11.6.
- 11.3 BID NOT SECURED IN ACCORDANCE WITH PARA 11.1(i) SHALL BE TREATED AS NON-RESPONSIVE AND SHALL BE REJECTED BY THE TENDERING AUTHORITY.
- 11.4 The bid security of the unsuccessful bidder will be discharged/returned as promptly as possible as but not later than 30 days after the expiry of the period of bid validity prescribed by the Tendering authority, pursuant to Clause 12.
- 11.5 The successful bidder's bid security will be discharged upon the bidder's acceptance of the LOI/APO satisfactorily in accordance with clause 27 and furnishing the performance security.
- 11.6 The bid security may be forfeited:
- (a) If bidder withdraws his bid during the period of bid validity specified by the bidder on the Bid Form, or
 - (b) In case of a successful bidder, if the bidder fails:
 - i. To sign the contract in accordance with clause 28 or
 - ii. To furnish performance security in accordance with clause 28.2.
 - (c) In both the above cases i.e. 11.6 (a) & (b), the bidder will not be eligible to participate in the tender for same item for one year from the date of issue of LOI. The bidder will not approach the court against the decision of BSNL in this regard.

12. PERIOD OF VALIDITY OF BIDS:

- 12.1 Bid shall remain valid for 150 days after the date of bid opening prescribed by the Tendering authority, pursuant to Clause 18.1. A BID VALID FOR A SHORTER PERIOD SHALL BE REJECTED BY THE TENDERING AUTHORITY AS NON-RESPONSIVE.
- 12.2 In exceptional circumstances, the Tendering authority may request the bidder's consent For an extension to the period of bid validity. The request and the responses thereto shall be made in writing. The bid security provided under Clause 11 shall also be suitably extended. The bidder may refuse the request without forfeiting his bid security. In such case(s), his/her bid shall be rejected without forfeiting the bid security. A bidder accepting the request and granting extension will not be permitted to modify his bid.

13. i) POWER OF ATTORNEY:

- a. The power of attorney should be submitted and executed on the non-judicial stamp paper of appropriate value as prevailing in the respective states (s) and the same be attested by a Notary Public or registered before Sub-Registrar of the state(s) concerned.
- b. The power of Attorney is executed by a person who has been authorized by the Board of Directors of the bidder in this regard, on behalf of the Company/institution/body corporate.

ii) FORMAT AND SIGNING OF BID:

The bid shall contain no interlineations, erasures or overwriting except as necessary to correct errors made by the bidder in which case such corrections shall be signed by the person(s) signing the bid with date.

D. SUBMISSION OF BIDS:

14. SEALING AND MARKING OF BIDS:

SIGNATURE OF THE TENDERER WITH SEAL

- 14.1 The Bidders are specifically required to submit their offers in two parts, each in different sealed envelopes duly marked as-
- i. **“Envelope-A: (1) DD for Bid Security (2) DD for Cost of Bid Document (in case the tender document is downloaded from our website) & (3) Technical Bid”.**
 - ii. **“Envelope-B: Financial/ Price Bid”(Superscribed as financial bid)**

All the above two envelopes (A & B) should be submitted in a large cover.

- 14.2 Above two covers are to be sealed (Packing PVC Tape/Sealing Wax) and marked with PERSONAL SEAL. All the two covers **(A & B)** shall be kept in one outer cover which will also be sealed with PVC Tape/Wax and marked with personal seal.
- 14.3 If the envelopes are not sealed (Packing PVC Tape/Sealing Wax) and marked as required above, the bid is subjected for rejection in tender opening stage itself.
- 14.4 Envelope-A should contain (i) Bid Security as per clause-11 (ii) DD towards the Cost of Bid Document (if the tender document is downloaded from website) & (iii) Technical bid along with related document establishing bidders eligibility as per clause-10.
- 14.5 Envelope-B should contain Financial/ Price Bid i.e. the rates duly quoted by the bidder in the prescribed format **(Section-VII “Financial Bid”)**.
- 14.6 If any of the document required to be submitted in envelope A is found wanting, the concerned bid shall be rejected at the opening stage itself and the remaining envelope B will not be opened.
- 14.7 The envelopes should be addressed as :

(a) ***The Asst. General Manager (NWP-II)
O/o. General Manager (CMTS)
Odishaa Telecom Circle, BSNL
2nd Floor, Telephone Exchange Building,
BJB Nagar,Bhubaneswar-14, Odisha.***

i) Bear the item name i.e.(**ERECTION OF 40M NBFL GBT & IT'S ASSOCIATED WORKS IN ODISHA FOR GSM MOBILE PROJECT**), the tender number i.e.(**S-2/CMTS/TENDER-II/2013-2014**) and the words **‘DO NOT OPEN BEFORE 16:00 hrs. of 12.11.2013.**

(b) And shall indicate the name and address of the bidder to enable the bid to be returned unopened in case it is declared 'late'.

- 14.7.1 Bids shall either be sent by registered post or delivered in person. The responsibility for ensuring that Bids are delivered in time would vest with the bidder.
- 14.7.2 Bids delivered in person shall be delivered to above indicated address **on or before the time hours of due date**. The Tendering authority shall not be responsible if the bids are delivered elsewhere and after the due date and time.

15. SUBMISSION OF BIDS:

- 15.1 Bids (Envelopes A & B; all enclosed in another large envelope) must be received by the Tendering authority at the address specified under clause 14.8(a) not later than the time as specified in NIT.
- 15.2 The Tendering authority may, at its discretion, extend this deadline for the submission of bids by amending the Bid Documents in accordance with Clause 6 in which case all rights and obligations of the Tendering authority and bidders previously subject to the deadline will thereafter be subject to the deadline as extended.
- 15.3 The bidder shall submit his bid offer against a set of bid documents purchased by him for all or some systems/equipment as per requirement of the Bid Documents. He may include alternate offer if permissible as per the bid. However not more than one independent and complete offer shall be permitted from the bidder.

16. LATE BIDS:

SIGNATURE OF THE TENDERER WITH SEAL

Any bid received by the tendering authority after the deadline for submission of bids prescribed by the tendering authority, shall be rejected and returned unopened to the bidder.

17. MODIFICATION AND WITHDRAWAL OF BIDS:

- 17.1 The bidder may modify or withdraw his bid after submission provided that the written notice of the modification or withdrawal is received by the tendering authority prior to the deadline prescribed for submission of bids.
- 17.2 The bidder's modification or withdrawal notice shall be prepared, sealed, marked and dispatched as required in the case of bid submission in accordance with the provision of clause 14.A withdrawal notice may also be sent by Telex/FAX but followed by a signed confirmation copy, post marked not later than the deadline for submission of bids.
- 17.3 Subject to clause 19, no bid shall be modified subsequent to the deadline for submission of bids.

E. BID OPENING AND EVALUATION:

18. OPENING OF BIDS BY TENDERING AUTHORITY

- 18.1
- i. Bids shall be opened by the tendering authority in the presence of bidders or their authorized representatives who choose to attend, **at specified time and date**. The bidder's representatives, who are present, shall sign an attendance register. Authority letter shall be submitted by the bidder before they are allowed to participate in bid opening (The format as given in **Section-X of the Bid Document**).
- ii. The Tendering authority will first ensure the availability of Bid Security and cost of tender paper (if downloaded from website) and Technical BID in envelope 'A', if any of these are not available the remaining envelope will not be opened and the bid will be rejected at that stage itself.
- iii. **The Tendering authority shall check availability of required document in Technical BID. Evaluation of the technical bids in details shall be done by the tendering authority on a later date before opening of the financial/price bid.**
- iv. For technically responsive bids, the **Financial/ Price bids (Envelope-B)** will be opened on the due date and time.
- 18.2 Only one representative for any bidder shall be authorized and permitted to attend the bid opening.
- 18.3 The Bidder's names, Bid prices, Modifications, bid withdrawals and such other details as the Tendering authority, at its discretion, may consider appropriate; will be announced at the time of opening.
- 18.4 The date fixed for opening of bids, if subsequently declared as holiday by BSNL the revised date of schedule will be notified. However, in absence of such notification the bids will be opened on the next working day, time and venue remaining unaltered.

19. CLARIFICATION OF BIDS:

To assist in the examination, evaluation and comparison of bids, the tendering authority may, at its discretion ask the bidder for the clarification of its bid. The request for clarification and the response shall be in writing. **However, no post bid clarification at the initiative of the bidder shall be entertained.**

20. PRELIMINARY EVALUATION:

- 20.1 Tendering authority shall evaluate the bids to determine whether they are complete, whether any computational errors have been made, whether required sureties have been furnished, whether the documents have been properly signed and whether the bids are generally in order.
- 20.2 Prior to the detailed valuation, pursuant to clause 21, the tendering authority will determine the substantial responsiveness of each bid to the Bid documents. For purposes of these clauses, a substantially responsive bid is one which conforms, to all the terms and conditions of the Bid documents without material deviations. The tendering authority's determination of bid's responsiveness is to be based on the contents of the bid itself without recourse of extrinsic evidence.

- 20.3 A bid, determined as substantially non-responsive will be rejected by the tendering authority and shall not subsequent to the bid opening be made responsive by the bidder by correction of the non-conformity also the tendering authority shall not be bound to show the reasons/causes of rejection of the bid.
- 20.4 The tendering authority may waive any minor infirmity or non-conformity or irregularity in a bid, which does not constitute a material deviation, provided such waiver, does not prejudice or affect the relative ranking of any bidder.

21. EVALUATION AND COMPARISON OF SUBSTANTIALLY RESPONSIVE BIDS:

The tendering authority shall evaluate in detail and compare the bids previously determined to be substantially responsive pursuant to clause 20.

Arithmetical errors shall be rectified on the following basis. If there is a discrepancy between the unit price and total price that is obtained by multiplying the unit price and quantity, the unit price shall prevail and the total price shall be corrected by the tendering authority. If there is a discrepancy between words and figures, the amount in words shall prevail. If the bidder does not accept the correction of the errors, his bid shall be rejected. **In a tender, where number of items is more than one, price evaluation shall be on composite basis.**

Tendering authority may negotiate with L1 bidder only.

The evaluation formula of financial bid are as detailed below :

$$\text{'R' factor} = 1 + 2 + 3 + 4 + 5 + 6 + 7 + 8 + 9 + 10$$

Lowest bidder will be decided on the basis of 'R' factor.

22. CONTACTING THE TENDERING AUTHORITY:

Subject to Clause 19, no bidder shall try to influence the tendering authority on any matter relating to its bid, from the time of the bid opening till the time the contract is awarded. Any effort by a bidder to influence the tendering authority in the tendering authority's bid evaluation, bid comparison or contract award decisions shall result in the rejection of the bid.

23. AWARD OF CONTRACT:

(1). The total work may be distributed among two bidders including the L1 bidder at L1 rate.

(2). The tendering authority shall consider placement of orders for execute the work only on successful L1 bidder whose offer has been found technically, commercially and financially acceptable. The tendering authority reserves the right to counter offer price(s) against price(s) quoted by L1 bidder. All terms and conditions applicable to the L1 bidder are also equally applicable to the bidder/bidders, who will accept the counter offer for execution of work.

24. TENDERING AUTHORITY'S RIGHT TO VARY QUANTITIES :

a) BSNL reserves the right to increase or decrease up to 25% of the quantity specified in the schedule of requirements without any change in the unit price or other terms and conditions at the time of award of contract.

b) BSNL also reserves the right for placement of additional order up to 50% of the additional quantities of goods and services contained in the running tender/ contract within a period of twelve months from the date of acceptance of first APO in the tender at the same rate or a rate negotiated (downwardly) with the existing venders considering the reasonability of rates based on prevailing market conditions and the impact of reduction in duties and taxes etc and supplies to be obtained within delivery period scheduled afresh.

c) In exceptional situation where the requirement is of an emergent nature and it is necessary to ensure continued supplies or services from the existing venders, the tendering authority reserves the right to place repeat order up to 100% of the quantities of goods and services contained in the running tender /contract within a period of twelve months from the date of acceptance of first APO

in the tender at the same rate or a rate negotiated (downwardly) with the existing vendors considering the reasonability of rates based on prevailing market conditions and the impact of reduction in duties and taxes etc. Exceptional situation and emergent nature should be spelt out clearly detailing the justification as well as benefits accrued out of it and loss incurred in case this provision is not invoked and approved by the authority competent to accord administrative and financial approval for the procurement calculated on the basis of total procurement i.e. initial and proposed add-on quantity.

25. VALIDITY OF CONTRACT

The contract shall normally be valid for one year from the date of signing of the agreement with an option of extension for a further period of six months subject to a maximum of twelve months with same rate, terms and conditions.

26. TENDERING AUTHORITY'S RIGHT TO ACCEPT ANY BID AND TO REJECT ANY OR ALL BIDS

The tendering authority reserves the right to accept or reject any bid, and to annul the bidding process and reject all bids, at any time prior to award of contract without assigning any reason whatsoever and without thereby incurring any liability to the affected bidder or bidders on the grounds for the tendering authority's action.

27. ISSUE OF LETTER OF INTENT (LOI):

The issue of an LOI shall constitute the intention of the Tendering authority to enter into the contract with the bidder.

The bidder shall within 14 days of issue of the LOI give his unconditional acceptance to the terms & conditions of tender in writing along with performance security 5% of value of awarded work in conformity with **Section IX** provided with the bid documents.

28. SIGNING OF CONTRACT:

28.1 The issue of work order shall constitute the award of contract on the bidder only after production of original documents for verification.

28.2 Upon the successful bidder furnishing the performance security pursuant to Clause 27, the tendering authority shall discharge its bid security, pursuant to clause 11.

29. ANNULMENT OF AWARD:

Failure of the successful bidder to comply with the requirement of Clause 27 shall constitute sufficient ground for the annulment of the award and forfeiture of the bid security in which event the tendering authority may make the award to any other bidder at the discretion of the tendering authority or call for new bids.

30. COURT JURISDICTION:

The contract shall be governed by Indian Laws and Courts at Bhubaneswar/ Cuttack and will have the jurisdiction to entertain any dispute or claim arising out of this tender till issue of Work order

31 While all the conditions specified in the Bid Documents are critical and are to be complied. Special attention of bidder is invited to the following clauses of the bid document, non-compliance of any one of which shall result in out right rejection of the bid.

i. Clause 14.1 of Section II-The bids will be recorded/ returned unopened, if covers are not properly sealed with "Personal seal" of the bidder.

ii. Clause 11.1 & 12.1 of Section II- The bids will be rejected at opening stage if bid security is not submitted as per Clauses 11.1 bid validity is less than the period prescribed in Clause 12.1 mentioned above.

iii. Clause 2& 10 of Section II- If the eligibility condition as per clause 2, Section II is not met and/or documents prescribed to establish the eligibility as per Clause 10 of section II are not enclosed, the bids will be rejected without further evaluation.

iv. Section VII: Price schedule- Prices are not filled in as prescribed in price schedule.

v)

a) Before outright rejection of the bid for non-compliance of any of the provisions mentioned in clause 31 (i) and (ii) of section-II, the tendering authority may extend opportunity to the

SIGNATURE OF THE TENDERER WITH SEAL

Bidder(s)/Companies to explain it's/ their position. However if the person representing the company is not satisfied with the decision of the Bid-opening team, he/they can submit the representation to Bid-opening team immediately but in no case after closing of the tender process with full justification quoting specifically the violation of tender conditions, if any.

- b) The representations received in bid opening day shall be submitted to the competent authority for review if the bid opening team is satisfied with the arguments of the bidder(s)/companies mentioned in their representations and feel that there is prima-facie fact for consideration as early as possible and decision to this effect shall be communicated to the bidder company. If the reviewing officer finds it fit to open the bid of the petitioner, the bid(s) shall be opened by giving three (working) days notice to all the participating bidders to give opportunity to desirous participants to be present on the occasion.
 - c) The tendering authority shall not return the bids submitted by the bidders on the date of tender opening even if it is liable for rejection. Such bids shall be kept preserved in sealed cover as submitted by the bidder(s), however; desirous representatives of the participating bidders/ companies present on the occasion may put their signatures on the sealed envelopes if they intend to do so. Bids found liable for rejection will be returned to the bidders after issue of work order against instant tender.
- 32.** Tendering authority reserves the right to disqualify the bidder for suitable period who habitually failed to complete the work in time. Further, the bidders whose works do not perform satisfactorily in the field in accordance with the specifications may also be disqualified for a suitable period as decided by the tendering authority.
- 33.** Tendering authority reserves the right to black list a bidder for a suitable period in case he fails to honor his bid without sufficient grounds.
- 34.** The bidder should give a certificate that none of his / her near relative is working in the units as defined below where he/she is going to apply for the tender. In case of proprietorship firm certificate will be given by the proprietor. For the partnership firm, certificate will be given by all the partners and in case of limited company by all the directors of the company excluding Government of India/ Financial institutions nominees and independent non-official part time Directors appointed by Government of India or the Governor of the state. Due to any breach of these conditions by the company or firm or any other person, the tender will be cancelled and bid security will be forfeited at any stage whenever it is noticed and BSNL will not pay any damage to the company or the firm or the concerned person.

The company or firm or the person will also be debarred for further participation in the concerned unit.

The near relatives for this purpose are defined as :-

- (a) Members of a Hindu undivided family.
- (b) They are husband and wife.
- (c) The one is related to the other in the manner as Father, Mother, Son(s) and Son's wife (Daughter-in-law), Daughter(s) and Daughter's husband (Son-in-law), Brother(s) and Brother's wife, Sister(s) & Sister's husband (Brother-in-law).

The format of the certificate to be given is, "I.....
.....S/o....."

here by certify that non of my relative(s) as defined in the tender document is/are employed in BSNL unit as per details given in tender document. Incase at any stage, it is found that the information given by me is false/incorrect, BSNL shall have the absolute right to take any action as deemed fit without any prior intimation to me."

SECTION-III
CONDITION OF CONTRACT

1. DEFINITIONS:

The contract means the document forming the tender and acceptance thereof and the formal agreement executed between the BSNL and the contractor together with the documents referred to therein including the conditions of contract, the specifications, designs, drawings and instruction issue from time to time by the Divisional Engineer in-charge and all these documents taken together shall be deemed to form one contract and shall be complementary to one another. In the contract, the following expressions shall unless where the context otherwise required, have the meaning hereby respectively assigned to them.

- a) The expression WORK or WORKS shall unless there be something either in the subject or context repugnant to such construction be construed and taken to mean the works by or by virtue of the contract to be executed whether temporary or permanent and whether original, altered, substituted or additional.
- b) The SITE shall mean the land and /or other places on which work is to be executed under the contract.
- c) SITE ENGINEER shall mean any supervisory officer of the Bharat Sanchar Nigam Limited who may be placed by the Divisional Engineer as in charge of the work at site at any particular period of time.
- d) The contractor shall mean the individual or firm or company whether incorporated or not, undertaking the works and shall include the local personal representative or such individual or the persons composing such firm or company or the successors of such firm or company and the permitted assignees or such individual or firm or firms or company.
- e) The Divisional Engineer in-charge means, the Divisional Engineer who shall supervise and shall be in-charge of the work, at any time or who shall sign the contract on behalf of the BSNL.
- f) The Bharat Sanchar Nigam Limited means, a Government of India Enterprise under Ministry of Communication & IT. All references of:
 - i) Company
 - ii) G.M. (CMTS)
 - iii) D.G.M.(CMTS)
 - iv) Divisional Engineer
 - v) Sub-Divisional Engineer
 - vi) Junior Telecom Officer
 - vii) Accounts Officer

In various clauses shall be taken to mean respectively.

2. PERIOD OF VALIDITY

The approved rates will remain valid for a period of one year from the date of execution of agreement with an option of extension of a further period of six months subject to a maximum of twelve months on the same rate, terms and conditions.

3. LABOUR / MATERIAL / EQUIPMENTS / SUPPLIES

- a. The contractor shall be responsible for the transportation, storage and safe custody of all materials supplied to him by the company. The contractor shall satisfy himself regularly the quality and quantity of the materials supplied to him and he will be responsible for any subsequent deterioration and discrepancy (inclusive of theft) in the quality/quantity of the materials.
- b. The contractor shall submit a proper account every fortnight of all the materials supplied to him by the company and those consumed for items of work. Any discrepancy or difference between the material issued to the contractor and those consumed in the work as per the company's calculation (which shall be final) will be charged to the contractor or deducted from his bills at cost price inclusive of any escalation and including freight, handling charges, storage charges etc. plus 17.5 % company's charges.

SIGNATURE OF THE TENDERER WITH SEAL

- c. Upon completion of the work, the contractor shall return to the company at the latter's designated store in good condition free of charges, any unused materials that were supplied by the company.
- d. The contractor while taking delivery of materials supplied by the company at the designated places shall thoroughly inspect all items before taking them over. Once the owner furnished materials are made over to the contractor it shall be his responsibility for safe custody till commissioning and taking over of the completed work by the company. Any pilferage, damage etc to the materials, furnished by the company shall be at the risk and cost of the contractor and charges for such unaccounted materials shall be decided in accordance with (b) above. Claim for shortage material will not be entertained on later stage if not pointed out at the time of taking over the materials.
- e. Notwithstanding any thing else herein stated, the contractor shall furnish and pay for all supervision, labour tolls, supplies construction equipment and consumable materials including explosive as may be necessary for the performance of the work and the cost of these shall be included in the unit construction prices quoted by the tenderer at the time of submitting his tender and payable to the contractor.

4. GUARANTEES

In addition to any and all other guarantees and warranty mentioned in the contract documents, the contractor guarantees that the entire work will be done in a satisfactory manner and free from any defects in workmanship and finish and in conformity in all respects with the specifications and direction. The contractor also undertakes to repair or replace, as the case may be at his own cost and risk any part of the works which may be damaged or that may develop any defects due to bad workmanship or otherwise due to the fault of the contractor within a period of one month notice.

5. METHOD AND MANNER OF PERFORMANCE

The contractor shall be an independent contractor and shall have complete charge of the men engaged in the performance of the works to be performed hereunder and shall perform the works in accordance with his own methods and his own risk, subject to compliance with the contract execute the works in the best and most substantial workman like manner and both as regards material and otherwise in respect in strict accordance with the contract documents or such other additional particulars, instructions and drawings as may be found requisite to be given during carrying out the works, enforce good order among his employees and shall not employ on the work any unfit person or any one not capable or not properly qualified to properly perform the work assigned to him. The contractor shall also not employ in respect of the works any employee that the Divisional Engineer/Site Engineer may for any reason object to.

6. INSURANCE

Without limiting any of his other obligations or liabilities, the contractor shall at his own expense, take and keep comprehensive insurance including third party risk for the plant, machinery, materials etc. brought to the site and for all the work during the execution. The contractor shall also take out workman's compensation insurance as required by law and undertake to indemnify and keep indemnified the BSNL from and against all manner of claims and demands and losses and damages and cost (including between attorney and client) and charges and expenses that may arise in regard to the same or that the BSNL may suffer or incur with respect to and/or incidental to the same.

7. SUB-CONTRACTOR

- a. No sub contract in any circumstance is permissible.
- b. The contractor shall indemnify and save harmless to the BSNL from and against all actions, suits, proceedings, losses, costs damages, charges, claims and demands what so ever, either in law or in equity and all cost (inclusive between attorney and client) and charges and expenses that the BSNL may sustain out of or incidental (to in connection with any act (s) or commissions) of the contractor, his agents, employees.

8. REPRESENTATIVE OF THE BSNL

The BSNL shall be represented by the Divisional Engineer who will be in charge of the works. BSNL's representative in works site shall be the Engineer in-charge or such other representative

SIGNATURE OF THE TENDERER WITH SEAL

as the Divisional Engineer may from time to time designate in writing. The Engineer in-charge and/or his assistant or nominee shall inspect the work and materials of the contractor or the contractor's representative. Notice given in writing by the Divisional Engineer in-charge or by the Site Engineer and such other representatives as the Divisional Engineer may designate in writing shall be deemed to be authorized to represent the BSNL in respect of the agreement's representatives, as aforesaid, which in within his power shall be binding on the contractor.

9. REPRESENTATIVE OF THE CONTRACTOR

The contractor shall furnish to the BSNL the scheme of his intended organization for the contracted work, naming his superintendent. The contractor shall have on each site a superintendent, being authorized to represent the contractor on his designated section work, to whom the BSNL's representative can make known decisions, authorizations and interpretations. The contractor shall within 10 days after the execution of the contract/Agreement notify the BSNL the name(s) and address (es) of the Superintendent notified as aforesaid shall be promptly intimated in writing to the BSNL. Notices given in writing to the superintendents shall be deemed to be notices given to the contractor. The contractor shall also have a manager fully authorized to represent contractor on matters involving more than one section of work notification in respect of whom shall like wise be given to BSNL and who shall likewise be the contractor's representative in terms aforesaid. Failure to submit the list of personnel will attract cancellation of contract and forfeiture of EMD.

10. INTERPRETATION OF THE CONTRACT DOCUMENT

The Divisional Engineer and the contractor shall in so far as possible by mutual consultation try and decide upon the meaning and intent of the contract document. In case of disagreement the dispute will be referred to the sole arbitrator as provided in the contract. It shall be the contractor's responsibility to thoroughly familiarize all of his supervisory personnel with the contents of all the contract documents.

11. CHANGES AND EXTRA WORK

- a) Change as used herein means a substitution for, or omission of, any work or other requirements within the general scope of the work, the performance of or compliance with which is contemplated by the Contract Documents.
- b) "Extra work" as used herein means any work or compliance with any requirements, other than a change which is not, expressly or implied contemplated by the Contract Documents, and which is necessary to be performed for the proper completion of the contracted work. For the purpose of clarification, it is declared that, any work or operation which shall be necessarily incidental to the proper performance of any item of work or part thereof shall be deemed to have been by implication provided for in the relevant item of work or part thereof and shall not constitute extra work.
- c) The G.M. (CMTS) may, at his absolute discretion can make a change in any part of the work provided for the Contact if required with specific approval of the CGM as the case may be, and in such cases the contractor is bound to do such works.
- d) The Contractor shall not undertake or make any change or do any work under this contract unless he has received written instructions from Engineer-in-Charge.
- e) The Contractor shall not be entitled to any compensation in addition to the contract price for the performance of any work not envisaged under the contract, unless prior to the performance of such work he has received from the Engineer-in-Charge written authorization to perform such work.
- f) For extra work within the scope of this contract, the contractor will receive extra compensation on the basis of a lump sum unit price as may be agreed upon in advance between the Divisional Engineer and the Contractor. On the other hand, extra work can be executed separately out side the purview of the contract also on quotation basis by any agencies subject to financial limitations.
- g) In cases, of such of the works, where an interpolation of the rates are possible such rates shall be accepted by both the parties.
- h) If the altered, added or substituted work includes any work for which no rates are specified in the contract for the work can be derived from similar class of work in the contract, then such work shall be carried out at the rate determined by the Divisional-Engineer-in-Charge on the basis of the prevailing market rates where the work was done.
- i) If the rate for the altered, added or substituted work cannot be determined in the manner specified above, then the contractor shall within seven days of the date of receipt of order to carry out the work, inform the Divisional-Engineer-in-Charge of the rate which it is his intention to charge for

SIGNATURE OF THE TENDERER WITH SEAL

such class of work supported by analysis of the rate or rates on claimed, and the Divisional-Engineer-in-Charge shall determine the rates on the basis of prevailing market prices and pay the Contractor accordingly. However, the Divisional-Engineer-in-Charge by notice in writing will be at liberty to cancel the order to carry out such class of work and arrange to carry it out in such manner, as he may consider re-advisable.

12. QUALITY OF WORK

The BSNL shall be the final judge of the quality of the work and the satisfaction of the standards in respect thereof set forth in the contract documents. Laxity or failure to enforce compliance with the contract documents by the BSNL and/or its representative shall not manifest a change or intent of waiver, the intention being that, notwithstanding the same, the contractor shall be and remain responsible for complete and proper compliance with the contract documents and the specification therein. The Divisional Engineer has the right to prohibit the use of men and any tools, materials or equipments, which in his opinion do not produce work or performance, meet the requirement of the contract documents. The contractor should provide necessary assistance or labor for checking of tower work done for test check and measurement etc. by company's authorities.

13. PROTECTION OF WORK

The contractor shall be responsible for all materials furnished or supplied by the BSNL while in the Contractor's custody whether, or not installed in the work.

14. NOTIFICATION

The contractor shall give in writing to the proper person or authorize with a copy to the Divisional Engineer such notification, as may be mandatory or necessary in connection with the commencement, suspension, resumption, performance and/or completion of the contracted work. All notices shall be given sufficiently in advance of the proposed operation to permit proper correlation of activities and the contractor, shall keep all proper persons or authorities involved regularly advised of the progress of operations through out the performance of the work together with such other information and/or supporting figures and data as may from time to time be directed as required.

15. DELAYS IN CONSTRUCTION

The BSNL will make every reasonable effort to furnish materials required to be furnished by it under the Contract and 'Right of User' including the permits from Govt/Individual or any other agency required to be furnished by the BSNL under the Contract and made available in due time so as not to delay construction. The BSNL will, however not be liable to the contractor for any losses or damages costs, charges or expenses that the contractor may in any way sustain suffer due to delay in making the above available. However, an extension in time schedule may be admitted on the above reasons.

16. SHUT DOWN ON ACCOUNT OF WEATHER CONDITION

The contractor shall not be entitled to any compensation whatsoever by reason of suspension of the whole or any part of the work made necessary by the BSNL or deemed advisable on account of bad weather conditions or other force major conditions.

17. REFUNDS OF SECURITY DEPOSITS

- a) The Security Deposit or a part thereof or such balance thereof if any, as may remain after deduction there from in respect of any out standing bills of the contractor to the BSNL shall be paid back to the contractor after satisfactory guarantee period of one year from the date of satisfactory completion of the work and final acceptance by the BSNL or earlier at the discretion of the BSNL. The contractor shall remain liable to the BSNL in respect of any shortfall and or discharge liabilities notwithstanding return of Security Deposit or any part thereof.
- b) No interest will be payable on the Earnest Money or the Security Deposit or amounts payable to the contractor under the contract.
- c) Refund of the Security Deposit is subject to full and final settlement of the Final bill for the works contract executed under one contract.

18. INSPECTIONS AND TESTING

The Divisional Engineer or his representative or any of his superior officer or officer in charge of acceptance test shall have free access to the site at all times for inspection. The contractor shall render to the representative of the company all possible assistance and facilities for the purpose.

19. PROTECTION OF LIFE AND PROPERTY AND EXISTING FACILITIES

- a) The contractor is fully responsible for taking all possible safety precautions during preparation for and actual performance of the works and for keeping the construction site in a reasonable safe condition. The Contractor shall protect all life and property from damage or losses resulting from his construction operations and shall minimize the disturbance and inconvenience to the public.
- b) The Contractor shall be solely liable for all expense for and in respect of repairs and damage occasioned by injury of or damage to such underground and above structures indemnified the Government from and against all actions, cause or actions, damages, claims and demands what-so-ever, either in law or in equity and all losses and damages and costs (inclusive between attorney and clients charges and expenses in connection there with and/or incidental thereto).
- c) The current market value of any commodities list as a result of any damage to the aforesaid existing facilities shall be paid by the contractor together with such additional sums necessary to liquidate the personnel or property damages, resulting there from.
- d) The tower maintenance and associated works has to be executed through skilled labour engaged for such works are to be adequately secured.
- e) The Contractor must take all safety measures to prevent any kind of accident.

20. INDEMNITIES

- a) The Contractor shall at all times hold the company harmless and indemnify them against all actions, claims and demands of every nature and description brought or procured against the BSNL, its officers, and employees and forthwith upon demand and without protest or demur to pay to the BSNL any and all losses and damages and cost (inclusive between attorney and client and all cost incurred in endorsing this or any other indemnity or security which the BSNL may now or at any time have relative to the work or the contractor's obligations or in protecting or endorsing its right in any suit or other legal proceeding, charges and expensed and liabilities resulting from or arising out of or in any way connected with or incidental to the operations caused by the contract documents. In addition the contractor shall reimburse the government or pay to the BSNL forthwith on demand without protest or demur all cost charges and expenses and losses and damages otherwise incurred by it in consequence of any claims demands and actions which may be brought against the BSNL arising out of or incidental to or in connection with the operation covered by the contract.
- b) The contractor shall at his own cost at the BSNL's request defend any suit or other providing asserting a claim covered by this indemnity, but shall not settle, compound or compromise such suit or other finding without first consulting the BSNL.

21. COMPLIANCE WITH LAWS AND REGULATIONS

During the performance of the works the Contractor shall at his own cost and initiative fully comply with all applicable laws of the land and with any and all applicable By-laws, Rules, Regulations and orders and any other provisions having the force of law made or promulgated or deemed to be made or promulgated by BSNL, BSNL's agency or company, Municipal Board, BSNL or other regulatory or Authorized Body of Persons and shall provide all certifications of compliance therewith as may be required by such applicable law, By-laws, Rules Regulations, orders and /or provisions. The Contractor shall assume full responsibility for the payment of all contributions and pay roll taxes, as to its employees, servants or agents engaged in the performance of the work specified in the Contract documents. If the Contractor shall require any assignee or sub-contractor to whom any portion or the work to be performed hereunder or may be assigned, sub-leased or sub-contracted to comply with the provisions of the clause and in this connection the contractor agrees as to undertake to save and hold the BSNL harmless and indemnified from and against any/all penalties, actions, suits, losses and damages, claims and demands and costs (inclusive between attorney and client) charges and expenses whatsoever arising out or occasioned, indirectly or directly, by failure of the Contractor or any assignee or sub-contractor to make full and proper compliance with the said by laws, Rules, Regulations, Laws and Order and Provisions as aforesaid.

22. OPTIONAL TERMINATION BY BSNL (OTHER THAN DUE DEFAULT OF CONTRACTOR)

- a) The BSNL may, at any time, at its option cancel and terminate this contract by written notice to the contractor in which case the contractor shall be entitled to payment for the work done up to the time of such cancellation and a reasonable compensation in accordance with the contract prices for any additional expenses already incurred for balance work, exclusive of purchases and/or hire of material, machinery and other equipment for use in or in respect of he work.
- b) In the event of the termination of the contract, the contractor shall forthwith clear the site of all the contractors' materials, machinery and equipments and hand over BSNL or as the BSNL may direct.

SIGNATURE OF THE TENDERER WITH SEAL

- c) The BSNL may, at its option, cancel or omit the execution of one or more items of work under this contract, and any part of such item(s) without any compensation whatsoever to the Contractor.

23. TAXES AND DUTIES

Contractor shall pay all rates levies, fees, royalties, taxes and duties except service tax payable or arising from out of by virtue of or in connection with and/of incidental to the contract or any of the obligations of the parties in terms of the contract documents and/or in respect of the works or operations or any part thereof to be performed by the contractor and the contractor shall indemnify and keep indemnified the BSNL from and against the same or and default by the contractor in the payment thereof. Service tax will be paid extra by BSNL wherever applicable as per rate in force.

24. BREACH OF CONTRACT

The "Divisional-Engineer-in-charge" may without prejudice to his right against the contractor in respect of any delay or inferior workmanship or otherwise or to any claims, damage in respect of any breaches of the contract and with out prejudice to any rights or remedies under any of the provisions in this contract or other wise and whether the date of completion has or has not elapsed by notice in writing absolutely determine the contract in any of the following cases.

- i) If the contractor having been given by the Divisional-Engineer-in-charge a notice in writing to rectify reconstruct or replace and defective work or that the work is being performed in any inefficient or otherwise improper or un workman like manner omits to comply with the requirement of such notice for a period of seven days there after or if the contractor delays or suspend the execution of the work so that either in the judgment of Divisional-Engineer-in-charge (which shall be final and binding) he will be unable to secure completion of the work by that date.
- ii. After giving notice to the contractor to measure up the work of the contractor and to take such part thereof as shall be unexecuted out of his hands and to give it to another contractor to complete in which case any expenses which may be incurred in excess of the sum which would have been paid to the original contractor if the whole work had been executed by him of the amount of which excess the certificate in writing of the Divisional-Engineer-in-Charge shall be final and conclusive) shall be borne and paid by the original contractor and may be deducted from any money due to him by Government under his contract or any other account whatsoever or from his security deposit or proceeds of sales thereof a sufficient part thereof as the case may be. The contractor whose work has been rescinded due to breach of contract and carried out through another contractor does not have any right to initiate any legal proceedings to stall the work.
- iii. In the event of any one or more of the above courses being adopted by the Divisional-Engineer-In-Charge the contractor has no claim for having any loss sustained by him by reason of his having purchased or procured any materials or entered into any agreements or made any advances on account or with a view to the execution of the work or the performance of the contract. And in any case action is taken under any of the provisions aforesaid the contractor shall not be entitled to recover or be paid any sum for any work thereto or actually performed under this contract unless and until the Engineer-in-charge has certified in writing the performance of such work and the value payable in respect thereof and he shall only be entitled to be paid the value so certified.
- iv) In any case in which any of the powers conferred upon the Divisional Engineer in-charge by clause 25 thereof shall have become exercisable and the same shall not be exercised, thereof shall not constitute a waiver of any of the conditions hereof and such power shall not withstanding be exercisable in the event of any future; case default by the contractor and the liability of the contractor compensation shall remain unaffected. In the event of the Engineer-in-charge putting in force all or any of the powers vested in the preceding clause, he may if he so desires after giving a notice in writing to the contractor taken possession of (or at the sole discretion of the Divisional Engineer in-charge which shall be final) use as on hire (the amount of the hire money being also in the final determination of the Divisional Engineer in-charge) all or any tools, plant, materials, and stores, in or upon the works or the site thereof, belonging to the contractor, or procured by the contractor intended to be used for the execution of same and amount at the contract rates, or in the case of these not being applicable at current market rates to be thereof shall be final otherwise the DE, in-charge whose certificate thereof shall be final otherwise the DE, in-charge by notice in writing may order the contractor of his clearance, of tools, plant, materials or store from the premises (within a time to be specified in such notice) and in the event of contractor failing to comply with any such requisition, the DE may remove them all at contractor expenses or sell them by auction of private sale on account of contract and at his risk in all respects and the certificate of

the DE as to the expenses of any such removal and the amount of the proceeds and expenses of any such sale shall be final and conclusive against the contractor.

- v) If the contractor shall desire extension of time for completion of the work on the grounds of his having been unavoidably hindered in its execution or any other ground, he shall apply in writing to the Divisional Engineer in charge within the work order period of hindrance on account of which he desires such extension as aforesaid, and the Divisional Engineer in charge shall if in his opinion (which shall be final) reasonable grounds have been shown therefore, authorized such extension of time if any as may in his opinion be necessary or proper.
- vi) If at any time after the commencement of the work GM(CMTS) shall for any reason whatsoever not require the whole work thereof as specified in the tender to be carried out, the Divisional-Engineer-in-charge shall give notice in writing of the fact to the Contractor who shall have no claim to any payment of concession whatsoever on account of any profit or advantage which he might have derived from the execution of the work in full, but which he did not derive in consequence of the full amount of the work not having been carried out, neither shall he has any claim for compensation by reason of any alterations having been made in the original specifications, drawings, designs and instructions which shall involve any curtailment of the work as originally contemplated. Provided that the Contractor shall be paid charges on the cartage only of materials actually and bonafide brought to the site of the work by the Contractor and rendered surplus as a result of the abandonment or curtailment of the work or any portion thereof and then taken back by the Contractor, provided however that the Divisional-Engineer-in-charge shall have in all such cases the option of taking over all or any such materials at their purchase price or at local current rates whichever may be less.

25. INSPECTION

- a. All work under or in course of execution or executed in pursuance of the contract shall at all time be open to the inspection and supervision of the Divisional Engineer in charge and his authorized subordinates, and the contractor shall at all times during the usual working hours, and at all other times at which reasonable notice of the intention of the Divisional Engineer in charge of his subordinate to visit the work shall have been given to the contractor, either himself be present to receive order and instruction, or have in responsible agent duly accredited in writing be present. Orders given to the contractor agent shall be considered to have the same force as if they have been given to the contractor himself. The work during its progress can also be inspected by the officer of the company from time to time.
- b. The contractor shall give not less than seven days notice in writing to the Divisional Engineer in charge or his subordinate in charge of the work before covering up or otherwise placing beyond the reach of measurements any work in order that the same may be measured and correct dimensions thereof be taken before the same is so covered up or placed beyond the reach of measurement and shall not cover up and place consent in writing of the Divisional Engineer in-charge or his subordinate in charge of the work shall within the aforesaid period or seven days inspect the work and if any work shall be covered up or placed beyond the reach of measurement without such notice having been given by the Divisional Engineer in charge's consent being obtained the same shall be uncovered at the contractor's expenses or allowances shall be made for such work or the materials with while the same was executed.

26. WORKMEN'S COMPENSATION

In every case in which by virtue of the provisions of Section 12, sub-section (i) of the workmen's compensation Act, 1923 BSNL is obliged to pay compensation to a workman employed by the Contractor, in execution of the works, BSNL will recover from the Contractor the amount of the compensation so paid; and without prejudice to the rights of the BSNL under Section 12 Sub-section (ii) of the said Act, BSNL shall be at liberty to recover such amount or any part thereof by deducting it from the Security Deposit or from any sum due by BSNL to the Contractor whether under this contractor or otherwise. Government shall not be bound to contest any claim made against it under Section 12 sub-section (i) of the said Act, except on the written request of the contractor and upon his giving to BSNL full security for all costs for which BSNL might become liable in consequence of contesting such claim.

27. LABOUR WELFARE

- a) In every case in which by virtue of the provisions of the contract labor (Regulation and Abolition) Act and of the Contract Labor (Regulation and Abolition) Central Rules 1971. Government is obliged to pay any amounts of wages to a workman employed by the contractor in execution of the works, or to incur any expenditure in providing welfare and health amenities required to be provided under the above said Act and the Rules, under PWD, or under the C.P.W.D. Contractor's Labour Regulations, or under the Rules framed by the Government from time to time for the protection of health and sanitary arrangements for workers employed by C.P.W.D. Contractors, BSNL will recover from the Contractor the amount of wages so paid or the amount of expenditure so incurred; and without prejudice to the rights of the government under the Contract Labour (Regulation and abolition) Act, BSNL shall be at liberty to recover such amount or any part thereof, by deducting it from the security deposit or from any sum due by BSNL to the contractor whether under this agreement or otherwise. BSNL shall not be bound to contest any claim made against it under of the said Act, except on the written request of the Contractor and upon his giving to the BSNL full security for all cost for which BSNL might become liable in contesting such claim.
- b) The Contractor shall obtain a valid license under the contract labour (R&A) Act and the Contract Labour (regulation & Abolition) Central Rules before the commencement of the work, and continue to have a valid license until the completion of the work.
- c) Any failure to fulfill this requirement shall attract the penal provisions of this contract arising out of the resultant non-execution of the work.
- d) No labourer below the age of eighteen years shall be employed on the work.

28. FAIR WAGES

- a) The Contractor shall pay to labour employed by him either directly or through sub-contractors, wages not less than fair wages as defined in the C.P.W.D. contractor's labour regulations or as per the provisions of the contract labour (Regulation and abolition) Act and the Contract Labour (Regulation and Abolition) Central Rules, wherever applicable.
- b) The Contractor shall, notwithstanding the provisions of any contract to the contrary, cause to pay fair wage to labour indirectly engaged on the work.
- c) In respect of all labour directly or indirectly employed in the works for performance of the contract's part of this agreement, the Contractor shall comply with or cause to comply with the Central Public Works Departmental Contractor's Labour Regulation made by the BSNL from time to time in regard to payment of wages, wage period, deduction from wages, recovery of wages not paid and deduction unauthorized made, maintenance of wages book or wage slips, publication of scale of wages and other terms of employment, inspection and submission of periodical returns and full other matters of the like nature of as per the provisions of the contract labour (Regulation and Abolition) Central Rules 1977 wherever is applicable.
- d) The Contractor shall comply with the provisions of the payment of Wages Act 1936, Minimum Wages 1948, Employees Liability Act 1938, Workmen's Compensation Act 1923, Industrial Disputes Act, 1947, Maternity Benefits Act 1961, and the Contractor's about (Regulation and Abolition) Act or the modifications thereof or any other laws relating thereto and the rules made there under from time to time.
- e) The contractor shall indemnify BSNL against payments to be made under and for the observance of the Laws aforesaid and the C.P.W.D. Contractor's Labour Regulations without prejudice to his right to claim indemnity from his sub-contractors.
- f) The regulations aforesaid shall be deemed to be a part of this contract and any breach thereof shall be deemed to be a breach of this contract.

29. OTHER LABOUR WELFARE MEASURE

- a) The Contractor shall implement the labour welfare measure enunciated in state P.W.D & C.P.W.D.
- b) The contractor shall also follow the safety method enunciated in C.P.W.D. safety codes.
- c) The Contractor shall comply with all the provisions of the Minimum Wages Act, 1948, Contract Labour (R&A) Act 1970, and rules framed and other labour laws affecting Contract Labour that may bring into force from time to time.

30. COMPENSATION FOR DELAY

- a) The time allowed for carrying out the work as entered in the work order schedule shall be strictly observed by the contractor. The work shall throughout the stipulated period of the Contract be proceeding with all due diligence and the Contractor shall pay as compensation in the form of liquidated damages of an amount equal to 1.5 (one and a half) percent of the amount of the work awarded for every one week or part there of delay in completion of work in all respects. "Provided

always that the entire amount of compensation to be paid under the provisions of this clause shall not exceed twelve percent on the tendered cost of the work.

- b) On any date the compensation payable as above reaches 10% of the estimated cost of the work, the Contractor should proceed with the work further only on getting a written instruction from DET that, he is allowed to proceed further with the work. It will be in the discretion of the DET to allow the Contractor to continue with the work on the basis of any written agreement reached between the Contractor and the Divisional Engineer one of the conditions of such agreement may be a stipulation for the contractor to agree for realization of compensation for delay at higher rate as may be approved by competent authority and agreed between the DET and the Contractor.
- c) However in a particular case, if the Divisional Engineer is satisfied based on the facts and circumstances of the case and all based on written representation that the contractor may make in this regard that the slow progress was due to the reasons beyond the control of the Contractor and for reasons not attributable directly or indirectly to contractor, the DET may have discretion to waive the realization of compensation for delay. Whenever such a decision has been taken, the Contractor should ensure that the DET has actually taken such a decision and it has been communicated to the Contractor in writing before proceeding further with the work.
- d) If after awarding the work, the work has not been commenced within 15 days of the award of the work, the Security Deposit will stand forfeited to the BSNL if so desired by Divisional-Engineer-in-Charge.
- e) If after commencement of the work, the contract is terminated for slow progress, in addition to recovery of compensation for delay the full security deposit shall also be forfeited to the BSNL if so desired by Divisional-Engineer-in-Charge.

31. EXTENSION OF TIME LIMIT

- a) It will be the discretion of the Divisional Engineer to revise or modify or extend the time limits specified for the total work awarded to the Contractor or to further specify the quantum of work to be completed a specified period, provided a written request has been received from the contractor explaining the reasons for which such extension of time is asked for, the Divisional Engineer in the particular case is convinced and satisfied that, such extension or revision modification is in the interest of the BSNL. In such cases, payment of liquidated damages as compensation, for delay becomes liable based on such revised or modified or extended time limits and the conditions under which such extension or modification or revision has been made.
- b) The fact that the time schedule has been altered at a certain stage of the work on a request from the Contractor as mentioned in the preceding paragraph does not imply that, whatever liquidated damages have accrued up to the date of such revision is not realizable from the Contractor.
- c) The Divisional Engineer while revising the time schedule may further specify and make it one of the conditions for such modification of the time schedule that, the contractor may be prepared to pay further liquidated damages for any delay in completion of the work even beyond the periods specified in the modified time schedule.
- d) In case of slow progress of the work in a section which has been awarded to a particular contractor and the public interest does not permit extension of time limit for completion of the work, the divisional engineer will have the full right to order that the scope of the contract may be restricted to such fraction of the work and award that balance of the work to any other contractor or to execute the work by the company, as is convenient or expedient to the BSNL.
- e) In such an event no compensation shall be payable by the BSNL to the contractor towards any inconvenience or loss that he may be subjected to as a result of such an action by the BSNL.
- f) Liquidated damages for delay of the work shall be recoverable from the bills of the contractor and/or by adjustment from the security deposit. The amount of liquidated damages will 1.5% of the amount of work awarded for every one week or part there of delay in execution subject to a maximum of 12% of the tendered cost of the work. However, adjustment from the security deposit will be made only either when the contract has been terminated or at the time of final settlement of the bills on completion of the work.

32. SITE INVESTIGATIONS AND REPRESENTATION

- a) The contractor shall satisfy himself as to the nature and locations of the general and local conditions particularly those bearing upon transportation, handling and storage of materials, availability of labour,

SIGNATURE OF THE TENDERER WITH SEAL

water, power and roads and uncertainties of weather, river stages or similar physical conditions at the site, the confirmation and conditions of the ground, the character of equipment and facilities needed preliminary to and during the execution of the work and all other matter which can in any way effect the work or the cost there under this contract. The contractor shall further satisfy as to the character, quality of surface and sub-surface materials any sub-surface structures to be encountered.

- b) The contractor shall investigate fully all hazards and safeguard against them and the contractor must provide for the protection of persons, animals and property.
- a) Any failure by the contractor to do so shall not relieve him of responsibility for estimating properly the difficult or cost of completely and satisfactorily performing the contract work.
- d) The BSNL assumes no representations made by any of its officers or agents or servants prior to the execution of the contract, and all previous negotiations and understandings are hereby canceled.

33. STORES SUPPLIED BY BSNL:

- a) All materials supplied to the contractors by the BSNL shall remain the absolute property of BSNL and shall not be removed from the site of the work except for use in the work and shall be at all times open to inspection by the engineer-in-charge. In case, the materials like pipes and accessories are taken delivery of by the contractor and stored at the site office/store of the contractor such site office store will also be treated 'as site' for this purpose. Any such material remaining unused at the time of the abandonment, completion and determination of the contract shall be returned to the engineer-in-charge at the place directed by him.
- b) In the event of the contractor being adjudged insolvent or going voluntarily into liquidation or having received order or other order under insolvency act made against him or, in the case of a company, of the passing of any resolution, or in the event of the contractor failing to comply with any of the conditions herein specified, the Divisional Engineer shall have the power to terminate the contract without previous notice.
- c) Contractors legal heirs/representatives shall not without the consent in writing of the divisional engineer, have the right to continue perform the duties or engagements of the contractor or under the contract, in case of his death. In the event of the contractor with the consent of divisional engineer, transferring his business, and in the event of the contractor being a company and being wound up any time during the period of this contract for the purpose and with the object of transferring its business to any persons or a company, the contractor, shall make it one of the terms and stipulations of the contract for the transfer of his properties and business, that such other person or company, shall not continue to perform the duties or engagements of the contractor under this contract and be subject to his liabilities there under.

34. WORK EXECUTION

- a) It is important that the work has to commensurate with detail drawing and specification. However, broadly the work constitutes tightening of nut/bolt, painting, fixing lightening arrestor, aviation lamps and other misc. works. A broad guidance of different items of work is given in the construction specification.
- b) The work will commence after getting the site clearance certificate from the company and on issue of work order by Divisional Engineer.

35. PRICE VARIATION

The BSNL shall not be responsible for any escalation on prices of labour or materials machinery, equipments etc. What-so-ever or any increase in duties, levies or taxes on respect there of what-so-ever and the Contractors rates and Contractors obligation shall remain unaffected by such escalation and/or increase.

36. FORCE MAJEURE

- a) In the event of either party being rendered unable by force measure to perform this contract, then the obligation of the party affected by such force measure shall be suspended for the whole period during which such case lasts and until normal operations are resumed and when such cause end, The execution of this Contractor must be measure with all responsible dispatch. Should the execution of this contract be suspended by force measures then a corresponding extension of the completion date shall be automatically granted. The occurrence of a cause of force measure, however, shall not relieve the government and its obligations to make payments in the Contractor for the work satisfactorily executed prior thereto. The term force measure as employed herein shall mean Act of God, war declared undeclared, hostilities, enemy actions, revolts, riots, legal lockouts, and illegal strikes, tidal

SIGNATURE OF THE TENDERER WITH SEAL

waves, forest fires, major floods, explosions, earth quakes, epidemics, sabotage, extra ordinary act and regulations of central or state BSNL or municipal bodies.

- b) Upon the occurrence of such cause and its termination, the party rendered unable as aforesaid shall notify the other party in writing within 72 hours of the beginning and ending dates, giving full particulars and evidence, if required.

37. PAYMENTS

- a) The contractor shall submit bill on completion of the work based on the verification by site –in- charge and DET –In-charge and has to submit the report of detail A/T by Circle AT group along with the bill.
- b) Income tax at the prevailing rates with applicable surcharge & education Cess for which the bill has been passed will be deducted as tax at source, under relevant INCOME TAX Rules. However, if any new legislation comes into effect for deduction of tax at source at any other rate, deduction will be made at that rate.
- c) Necessary Income tax Deduction certificate will be issued by Accounts Officer (Cash), Office of the General Manager (CMTS), Bhubaneswar detailing the amount so deducted as tax at source at the time of payment of each bill.
- d) VAT as applicable will be deducted.
- e) The bills are to be submitted in DUPLICATE and in the manner and form that may be prescribed by the Divisional Engineer. Payments will be made only by Account Payee cheque drawn on S.B.I. Bhubaneswar/RTGS on any Nationalized/Schedule Bank. The contractor has to intimate his bank account number and branch details for issuing the cheque.
- f) Any liquidated damages due shall also be recoverable from the bills submitted for payment, by the aforesaid officers.
- g) The Divisional Engineer will have right to recover liquidated damages for delay or slow progress of the work from the bills submitted for payment.
- h) The Security Deposit shall be considered for adjustment against liquidated damages only at the time of final conclusion of the contract and final settlement of account.
- i) The final settlement of the bills and refund adjustment/appropriation of any amount retained, the contractor shall be made fully free after the Divisional Engineer is satisfied that all the contractual obligations have been fully met and no amount remains due for recovery from the contractor on any count.
- j) The bill shall have to be submitted by the contractor within one month of the date of completion. 90% of the billed amount will be paid after successful completion of work.
- k) The 10% amount retained as security deposit will be refunded after one year of completion of the work on the basis of “No objection certificate” issued by DE- In charge of the work. Any defect noticed during this period has to be attended without any extra payment. The EMD retained as security deposit will be refunded after termination of the contract period.
- l) The contractor shall be required to correct all defects reported by Engineer in-charge. Further on neglect on the part of the Divisional Engineer or his representative, to confirm or reject inferior work, notwithstanding, final acceptance of the work or any part thereof by the company/the Divisional Engineer/Engineer in-charge or his representative shall not be construed to imply the acceptance of such work. The provisions of this clause shall not in any way affect or limit the contractor's liability under the undertakings and guarantee contained in the contract document.

38. TERMINATION OF CONTRACT

- a) The G.M. (CMTS), Bhubaneswar has the right to terminate the contract either partly or fully at any stage without assigning any reason by giving 10 days notice in writing to that effect and shall not be liable to pay any compensation to the contractor thereof.
- b) In the event of contractor failing to execute the contract to the satisfaction of G.M. (CMTS), Bhubaneswar / concerned DE, CMTS shall have the right (i) to reject or/and with hold payment for such quantity of work till such time the defect is rectified to the satisfaction of the G.M. (CMTS), Bhubaneswar / concerned DE, CMTS (ii) to terminate the contract as per Clause-38 (a) above.
- c) In case of death of contractor during the period of contract, G.M. CMTS, Bhubaneswar may at his opinion either immediately terminate the agreement or may require the surviving partner/legal heir of the contractor to complete the contract as per the original agreement.

39. DISPUTES AND ARBITRATION

- a) All disputes arising between the contractor and the divisional engineer out of this contract shall be referred to the sole arbitration of C.G.M.T., Odisha Telecom Circle, Bhubaneswar.

- b) In case parties are unable to reach a settlement by themselves the dispute should be submitted for arbitration in accordance with contract agreement.
- c) There should not be a joint submission with the contractor to the sole arbitrator.
- d) Each party should submit its own claim separately and may oppose the claim put forward by the other party.
- e) The onus of establishing his claim will be left to the contractor.
- f) His claim will be firmly resisted by utilizing all the evidence available with the BSNL.
- g) Once a claim has been included in the submission by the contractor, a retraction or modification thereof will be opposed.
- h) The "Points of Defence" will be based on actual conditions of the contract.
- i) The question whether these conditions are equitable shall not receive any consideration in the preparation of Defence"
- j) Claims in the nature of extra payments shall not be entertained by the Arbitrator, as these are not contractual.
- k) If the Contractor includes such claims in his submission, the act that they are not contra will be prominently placed before the Arbitration.
- l) In case the amount involved is heavy, the Divisional Engineer may be within his rights to conduct the Defense by the BSNL Pleader.
- m) The award of the Sole Arbitrator shall be final and binding on the parties to the dispute.
- n) Any defect noticed during one year of completion of the work will have to be attended by the contractor without any additional cost.

40. GENERAL

- 01. The tenders shall be evaluated by a committee to be appointed by the G.M. (CMTS), Odisha Telecom Circle, Bhubaneswar.
 - i) The G.M. (CMTS), Bhubaneswar shall evaluate the bids to determine whether they are complete, whether any-computational errors have been made, whether required sureties have been furnished, whether the documents have been properly signed and whether the bids are generally in order.
 - ii) If there is discrepancy between words and figures, the amount in words shall prevail. If the contractor does not accept the correction of errors, his bid shall be rejected.
 - iii) A bid, determined as substantially non-responsive will be rejected by the G.M. (CMTS), Bhubaneswar and shall not subsequent to the bid opening be made responsive by the bidder by correction of the non-conformity.
 - iv) The G.M. (CMTS), Bhubaneswar may waive any minor infirmity or non-conformity or irregularity in a bid, which does not constitute a material deviation, provided such waiver, does not prejudice or affect the relative ranking of the bidder.
 - v) The tender shall be evaluated based on the rates quoted in financial bid on the basis of overall lowest bidder for total work. In case of more than one tenderer at the same lowest rates, the tenderer who has got more experience shall be preferred over others.
 - vi) The G.M. (CMTS), Bhubaneswar shall not be responsible for any escalation in prices of labour or materials, machinery, equipment, etc. whatsoever or any increase in any duties, levies, or taxes in respect thereof whatsoever and the contractor rates and contractor's obligation shall remain unaffected by such escalation and/or increase.
- 02. The G.M. (CMTS), Bhubaneswar reserves the right to reject one or all the tenders without assigning any reason thereof.
- 03. The G.M. (CMTS), Bhubaneswar reserves the right to cancel/reject any tender if the same is found to be containing any false/fabricated document/statement. Original of all documents shall be produced, if required, at the time of purchase of tender documents for scrutiny without which documents will not be issued.
- 04. The G.M. (CMTS), Bhubaneswar reserves the right to apportion the total work amongst a number of contractors at the approved rates and on uniform terms and conditions.
- 05. Transportation of labour from the site to another site from one area to other areas will be the responsibility of the contractor.
- 06. All tools and tackles for the work shall be provided by the contractor.
- 07. The G.M. (CMTS), Bhubaneswar will not be responsible to provide residential accommodation to the labourers employed by the contractor. All arrangement in this regard will be the responsibility of the contractor.

SIGNATURE OF THE TENDERER WITH SEAL

08. The G.M. (CMTS), Bhubaneswar reserves the right to increase or decrease or delete the scope of the work without assigning any reasons.
09. Conditional and incomplete tenders are liable for rejection.
10. Tender without EMD will summarily be rejected.
11. The G.M. (CMTS), Bhubaneswar will not be responsible for any misprinting by the newspaper concerned. Tenderers are to contact the tendering authority and verify the facts in case of confusion.
12. Issue of tender document does not automatically mean that the tenderer is qualified for the award of the contract. These will be reviewed and examined during the evaluation of the bid.
13. The G.M. (CMTS), Bhubaneswar is not bound to accept the lowest tender.
14. The G.M. (CMTS), Bhubaneswar is not responsible for non-receipt/late receipt and loss of tender documents.
15. In case of any dispute arising out of the contract between the two contracting parties, the decision of the G.M. (CMTS), Bhubaneswar shall be final and binding.

SECTION -IV
CONSTRUCTION SPECIFICATION
&
JOB DESCRIPTION

THE WORK INVOLVES MAINLY

- A. Erection of Tower.
- B. Painting of Tower.
- C. Providing & fixing lightening Arrestor.
- D. Providing & Fixing Aviation Lamp.
- E. Providing & Fixing of Sign Board.
- F. Supplying of G. I. Nuts, Bolts and other missing Tower Materials.
- G. Segregation of Tower Material
- H. Lifting of Tower Materials.
- I. Providing Ring earth to towers
- J. Providing and fixing horizontal & vertical wave guide rack.

A) **ERECTION OF TOWER****GENERAL**

The method of tower erection will mainly depend on the tower height. In case of towers more than 40 mtrs. In height a steel pole shall be used as derrick for the lower portion of the tower. For towers less than 40 mtrs. In height and four upper parts of the tower more than 40 mtrs. in height, two steel poles shall be used as derricks for hoisting the material. Strong wooden poles may also be used when the weight of materials to be hoisted does not exceed two quintals.

1. Hand driven winch shall be used for hoisting materials for towers more than 40 mtrs. in heights, maximum weight of materials to be lifted upwards shall be taken as one tonne. Smaller towers may be erected without using a winch. Maximum weight of materials to be lifted in such cases will be restricted to two quintals.
2. Steel towers, steel or wooden poles, winch set of pulley hooks, steel ropes and other tools be inspected and approved by the officer-in-charge of work before these are used on work.
3. A list of tools to be arranged by contractor for tower erection is given in Annexure-I.

EXECUTION

1. Before tower erection reconfirmation shall be made of foundation dimensions and relative levels of tower foundation legs, which has been done by civil wing.
2. Tower members shall be arranged member by member and quantity checked according to drawings supplied, ladder, antenna platform, antenna fixture, W/G rack & lightening spike supplied are also tower members.
3. Winch shall be securely fixed on the ground in suitable position. The pulleys and winch shall also be oiled properly before used.
4. In case any members are bent or twisted, they shall be straightened up. Any minor ironwork e.g. filling, cutting, drilling, bending etc. will be carried out by the contractor at his own cost.
5. The tower erection work shall be carried out by observing correct erecting order and orientation of tower members. In assembling members shall be successively fitted on the position shown in the tower drawings. Precautions shall be taken so that the lifting weight may not exceed the weight limit already specified.
6. The members being hoisted shall be properly guided by swing-guy ropes. Care shall be taken to see that member do not strike against the foul with members already lifted.
7. Bolts and nuts shall be fitted in position as shown in the drawing as assembly progresses. Bolts in horizontal level shall be inserted from inside of towers and nuts applied on outside of the tower. Bolts in vertical line shall be inserted from beneath with nuts applied on upper side. While fitting the members, extra holes may be required to be made. The extra holes shall be made by the contractor at no extra cost by drilling method.

SIGNATURE OF THE TENDERER WITH SEAL

8. A set of two magneto telephones / walky-talky set should be used as erection progresses beyond a height of 40 mtrs. For communication between workers on the ground and those on the top.
9. The bolts nuts shall be tightened in the following order:

In the first place, first and second section of tower shall be assembled with bolts and nuts tightened tentatively. The first section and second sections have been assembled accurately. In the second place, the third section shall be assembled and bolts and nuts tentatively tightened. The second section shall be completely tightened after it has been confirmed that both of second and first section has been assembled accurately. The remaining part of the tower shall be assembled in the above manners.
10. The confirmation of accurate assembly of tower shall be carried out by checking verticality of tower by using Theodolite. A transit shall be set along each of the two lines crossing perpendicularly at the tower center, at suitable distance from that tower so that the full height of the tower can transited. The Theodolites shall be focused on the line connecting the centers of all the bolts at the cross section of cross members on each face and it shall be confirmed that this line is perpendicular against the ground. In case this is not so the portion shall be redressed before assembling upper part. The tower faces should be free from any tilt or twist.
11. After completion of erection work, verticality of tower shall be checked again and all the bolts and nuts shall also be rechecked for tightness.
12. During installation arrangements will have to be made by the contractor(s) for providing temporary construction lights as required under aviation regulations when tower reaches 150 ft. and beyond.
13. The erection of tower should be carried out during normal working hours of 10.00 AM to 6.00 PM
14. Lightening spike should be provided on the top of the tower.

15.
B)

PAINTING OF TOWER PAINT

Paints used should be synthetic enamels of the ISI mark best quality and anticorrosive. The paints of Johnson and Nicholson/Berger/Asian/Shalimar manufactured brand should only be used.

ORANGE & WHITE BAND

The confirm to the Civil Aviation regulation, the mast shall be painted in alternate bands of international orange and white terminating with orange at top and the bottom as shown in drawing to be supplied. The correct shade for international orange corresponds to "536 Poppy" as given in Indian Standards Instruction Publication" Indian Standard Colours for ready mixed paint I.S.5-1955.

PAINTING METHOD

1. Cleaning the mast members.
 2. Application of wash primer and zinc chromate primer.
 3. Applying two or more coats of paint.
1. Cleaning the tower members
Mast members supplied are not dipped galvanized. All dust, dirt, grease, seal and rust etc. must be removed. All the parts must be chipped wire brushed and dusted.
 2. Application of Wash and Zinc chromate Primer
After cleaning all the members, first coat of primer should be evenly applied. The first coat should be allowed to dry up completely before applying the second coat of primer. Each coat must be well brushed with the surface of members.
 3. Painting
When the mast is clean and dry the first coat of paint may be applied and must be well brushed into the clean surface. Care should be taken to see that paint is uniformly and evenly applied. 48 hours must be allowed to elapse before following on with the second coat of the same paint, care should be taken that the painting is not carried out at the hottest time of the day.

Special Remark : The painting shall be done carefully so that all the corners and corvices of the mast receive that paint and no bare surface is left exposed any where galvanized coating has got removed.
No driers such as Lithargo or turpentine are to be used. The practice of mixing kerosene oil with paints is strictly forbidden.

- C) PROVIDING & FIXING LIGHTENING ARRESTOR
Providing and fixing lightening arrestor at the top of the tower as per direction of Engineer-in-Charge. G. I. Pipe of 50mm dia and 2.5m long for fitting spike, 10mm dia Usha martin wire tope for supporting spike with all legs of the top of the tower, bull dog clamp for fixing wire rope of required number, drilling and welding charges including cost of G. I. Spike, required length of G.I. strip should be prepared for connection. One end of the G.I. strip should be connected to the lightening spike at the lower top and other end to the ring earth below ground. All materials are to be supplied by the contractor.
- D) PROVIDING & FIXING OF AVIATION LAMP
Solar base aviation lamp of reputed brands like GEC/Bajaj / Philips / AOL (BINAY) / CEMA/FREQUENCY /MICROTECH/AVAIDS TECHNOVATOR of 72 CD/SQM is to be provided and fixing in the tower by the contractor. The Aviation Lamp should be fitted at the specific point and height according to Civil Aviation Regulation. Warning light to be provided on the top of the tower.
- E) PROVIDING & FIXING OF SIGN BOARD
The contractor should supply Sign Board and fixing in all the towers. All the tower date indicating type of tower, its weight, height, date of completion etc. should be clearly written on a sign board of size 600 x 750mm by a professional painter. The board should be fixed with the tower at a convenient height to that it can be inspected easily etc. and as per direction of Engineer-in-charge.
- F) SUPPLYING OF G. I. NUTS, BOLTS AND OTHER MISSING TOWER MATERIALS
Supplying and fixing of G. I. Nuts and Bolts and other missing tower materials of required size for erection of tower as per direction of Engineer-in-Charge.
- G) SEGREGATION OF TOWER MATERIALS
Segregation of tower materials at Store before carriage as per check list approved by the department as a pre-check for any loss, damage, bend etc. complete as per direction of Engineer-in-Charge.
- H) LIFTING OF TOWER MATERIALS
Lifting of 40M NBFL tower materials from RTSD, Bhubaneswar to the site of work including cost of loading and unloading etc. is to be done by the contractor as per direction of Engineer-in-charge.
- I) RING EARTH TO THE TOWER
Ring earth as the name implies is an earthing system in the form of a ring armed the tower for providing greater contact area in the soil for grounding high surge current from tower due to lightning. The earthing system must meet the following specifications.
- i) Resistance to earth must be within permissible limit (<0.5 ohm) for particular application.
 - ii) The electrode buried in the ground must be
 - a) Having good electrical conductivity to carry highest specified surge current.
 - b) Immune to corrosive action of the soil all along.
 - c) Of sufficient mechanical strength to avoid any damage during installation.
 - d) Invert i.e. must not be source of eddy current flow due to galvanic corrosion.
 - iii) The earth electrode must have sufficient surface area in contact with the soil to offer low resistance path to current flow from tower to earth.
 - iv) Resistance of the earth connection must remain within specified limit through out various seasons of the year.

LAYING RING EARTH AROUND TOWER

A trench for primary ring, secondary ring and inter connections is dug as shown in figure. Size of trench is 45 cm wide of top 30cm wide at bottom with 1.5 Mtr depths. In rocky area depth must be at least 90cm. In black cotton soil depth must be more than 1.5 mtr to avoid cracking of soil in summer. The primary ring should be laid 1 Mtr away from the Tower base. Separation between primary and secondary ring should be at least 2Mtr.If there is no space for earthing as per specification then it should be decided by the concerned DE regarding the type of earthing with approval of G.M. (CMTS) Bhubaneswar. Material required for ring earth.

SIGNATURE OF THE TENDERER WITH SEAL

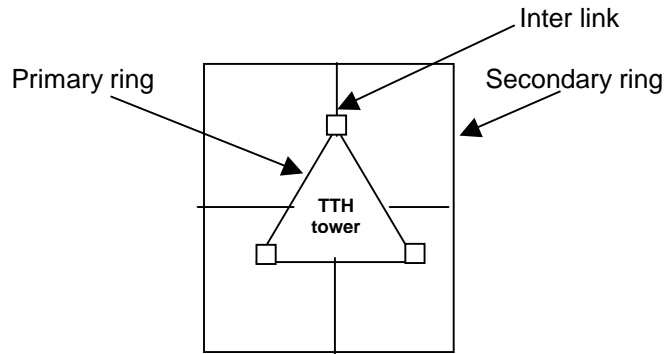

Electrode – GI. Strip 50mm x 5mm x 6 Mtr (standard length) are laid in ring trench and connected to tower leg with lead washer and GI nut bolts bottom of the trench should be filled with sieved good soil up to 10cm height and GI strip should be laid over it.

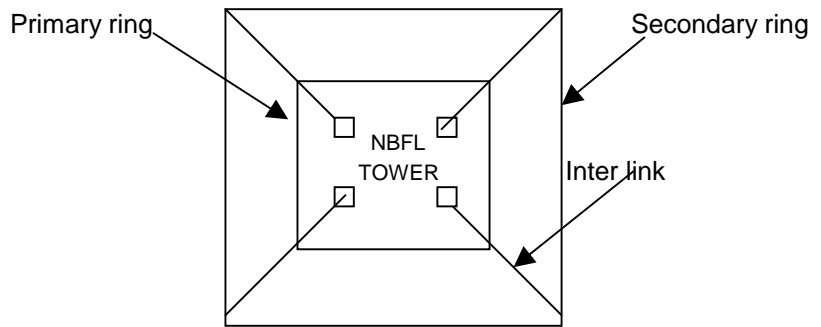

All connections are made by GI nuts and bolts.

For connecting GI with GI a lead strip 50mm x 3mm x 100mm with 13 mm dia holes as shown in figure should be placed in between GI strips for proper contact. The joint should be water tight and air tight to avoid corrosion. Joint should be wrapped with water proof Shalimar flash strip and sealed by bitumen. Each leg of the tower should separately connected by 1 end of 50mm x 5mm GI strip above the ground level and the other end of the same GI strip should be connected to ring earth. The connection of the GI strip to the tower leg is done by tower bolt and nuts with lead washer in between. The sheath of the power cable if armoured should be separately connected to the tower at the top end and to the ring earth at the bottom end by GI strips.

While laying GI strips for ring earth it should not be bent sharp by at right angles, but should be laid in a smooth curve of not less than one meter radius. After laying and fitting GI strips should be covered with finely sieved good quality soil up to 30cm height and should be properly rammed in layers. In case of rocky, hard morrum and black cotton soil the trench should not be filled with excavated soil. Foreign good earth which is fine and cohesive in nature should be used. While filling the trench, earth must be rammed in layers so as to give cohesiveness and compactness to the soil.

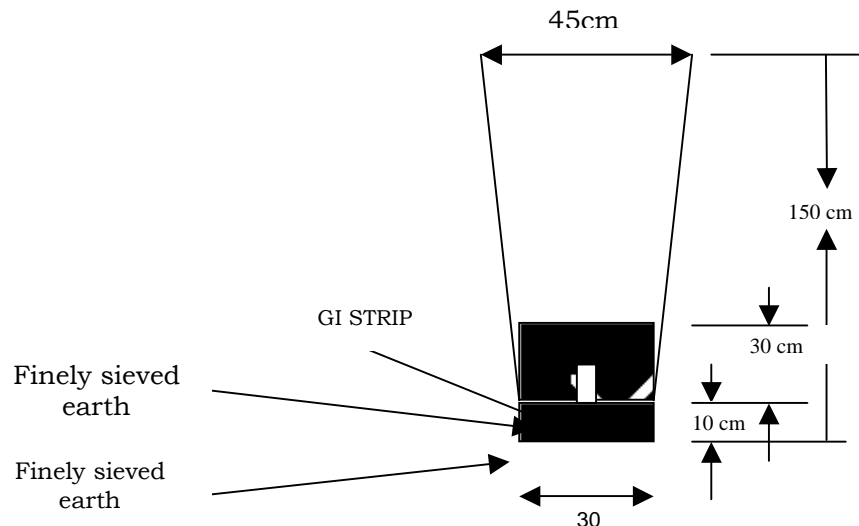

SIGNATURE OF THE TENDERER WITH SEAL

Cross section of Earthing trench

Restriction:

1. Chemical treatment of earth using salt etc are prohibited as this treatment is temporary and does not last long.
2. There is no need to separately run copper strip from lightning spike to the ring earth. The lightning spike should be properly connected with the tower itself, which works as a down conductor. To ensure good conductivity no structural member should be painted before assembly.
3. Earth conductor should not be encircled with metal clamps while taking it along the wall. This is essential to eliminate high inductive reactance (L & C) that would obstruct flow of surge current in case of lightning.
4. Earth conductors should not pass through any metallic conduit or pipe as this will increase surge impedance and obstruct flow of surge current.
5. Electrical earth of main transformer of 11 KV should be at least 6-7.5 Mtr away from the ring earth. Between line and transformer lightning arrester on all the 3 phases should be provided.

MEASUREMENT OF EARTH RESISTANCE & ITS LIMIT

Inter connective strips be provided in ring earth in a small manhole chamber so that ring should not be broken while measuring the value of earth resistance. Earth resistance should be less than 0.5 Ohm. In worst case it should not exceed 1 Ohm subject to sufficient justification by concerned field DEs.

J. (A) FABRICATION SUPPLY & FITTING OF HORIZONTAL WAIVE GUIDE RACK.

Horizontal Wave Guide rack of following specification required to be supplied by the contractor for connecting tower with the equipment room. Side arms - 40x6 GI angle with separation of 40mm, 40 x 6 mm GI flat 2M, @ 1.9 Kg per mtr, 3.8 Kg. Strap 25 x 6mm GI flat @ 1.2 Kg per mtr, Separation between adjacent straps 50mm, D' fitted over horizontal W/G rack prepared out of 25x5mm GI flat of 250x50x250mm with necessary holes at both terminals.

B) PROVIDING VERTICAL SUPPORT TO HORIZONTAL WAIVE GUIDE RACK.

Vertical support to the horizontal W/G rack should be as per departmental specification. It should be supplied and fitted properly on the ground by the contractor with required cement concreting in 1:2:4 proportion with finishing with cement mortar of 1:4 proportion of 12mm thickness. The top level of cement concreting grouting should be at least 250 mm above the ground level.

Side arms 40 x 40 x 5mm GI angle with separation of 500mm, Side arms 40 x 40 x 5mm GI angle @ 3 Kg per Mtr, 2 M, 6 Kg, Straps 25 x 5mm GI angle with separation of 500mm between adjacent straps, Straps 25 x 5mm GI flat @ 1 Kg per mtr, 1M, 1 Kg, GI angle 25x25x5mm of 600mm length with necessary holes should be welded to the top end for supporting the horizontal wave guide rack. The bottom end of the rack with similar GI angle welded to it without holes should be dipped in concrete for better supporting strength.

K. (A) Only fitting of Horizontal Wave Guide Rack and materials will be supplied by BSNL.

(B) Only fitting of Vertical support to Horizontal Wave Guide Rack and materials will be supplied by BSNL.

SECTION-V
BID FORM

Tender No.

Dated.

To

**The General Manager.(CMTS)
Odisha Telecom Circle, BSNL, Bhubaneswar.**

Dear Sir,

1. Having examined the conditions of contract and specifications including addenda Nos., the receipt of which is hereby duly acknowledged, we, undersigned, offer to execute the work, **Erection of 40M NBFL Ground Base Tower & It's Associated Works in Odisha for GSM Mobile Project** in conformity with the said drawings, conditions of contract and specifications for the sum shown in the schedule of prices attached herewith and made part of this bid.
2. If our Bid is accepted, we will obtain the guarantee of a Scheduled Bank for a sum not exceeding 5% of the contract sum for the due performance of the Contract.
3. We agree to abide by this Bid for a period of **180 days** from the date fixed for Bid opening and it shall remain binding upon us and may be accepted at any time before the expiry of that period.
4. Until a formal Work Order of Contract is prepared and executed, this Bid together with your written acceptance thereof in your notification of award shall constitute a binding contract between us.
5. Bid submitted by us is properly sealed and prepared so as to prevent any subsequent alteration and replacement.
6. We understand that you are not bound to accept the lowest or any bid, you may receive.

Dated this.....Day of.....2012

Signature of Authorized Signatory.....

In Capacity of

Duly authorized to sign the bid for and on behalf of.....

Witness:

Signature.....

Address.....

SECTION-VI**TECHNICAL BID**

01	Attested Xerox copy of valid contractor license	
02	Attested Xerox copy of PAN Card. In case of proprietor ship PAN should be in the Individual's name and in case of firm/partnership the PAN in firm's name	
03	Attested Xerox copy of Income Tax return for the financial year 2011-12.	
04	Attested Xerox copy of Valid Labour License	
05	Attested Xerox copy of Valid EPF registration Certificate with proof of up to date payment	
06	Attested Xerox copy of Valid Workman's compensation insurance or ESI certificate with proof of up to date payment	
07	Attested Xerox copy of Valid Service tax registration certificate with proof of up to date payment	
08	Attested Xerox copy of Experience certificate of successfully completed 40M or above height telecom tower erection & associated works in BSNL / MTNL/TCIL/ITI/Central Govt./Central PSU/State Govt./State PSU in last three financial years worth Rs.9,00,000/- or more issued by an officer not below the equivalent rank of TDM/ DGM/SE of BSNL.	
09	The Cost of Tender Paper worth Rs.525.00 & EMD for Rs.52,000.00 in favour of Accounts Officer (Cash), O/o.G.M. (CMTS), Bhubaneswar in shape of DD / BC from Nationalized/Scheduled Bank.	
10	The bidder should submit an undertaking to the effect that none of their relatives are working in BSNL as per the format in Section-XII	
11	Attested Xerox copy of authenticated partnership deed, in case of partnership firm and power of attorney to the representative of the firm to operate the tender	
12	Original "Power of Attorney" in case of person other than the tenderer has signed the tender document.	
13	Tender document should be signed by the bidder on all pages with seal.	
14	Information sheet.	
15	Financial Bid (Rate Sheet).	

Signature of bidder with seal

SIGNATURE OF THE TENDERER WITH SEAL

**SECTION-VII
FINANCIAL BID**

(RATE SHEET)

(To be submitted duly filled in by the bidder)

S/ N	DESCRIPTION OF ITEM	UNIT	QUOTED RATE	
			IN FIGURES	IN WORDS
01	ERECTION OF TOWER			
a)	40M NBFL GBT 8.4 MT	Per Tower		
02	PAINTING OF TOWER			
a)	40M NBFL GBT 8.4 MT	Per Tower		
03	PROVIDING & FIXING LIGHTENING ARRESTOR			
a)	40M NBFL GBT	EACH		
04	PROVIDING & FIXING OF AVIATION LAMP			
a)	40M NBFL GBT	EACH		
05	PROVIDING & FIXING OF SIGN BOARD			
		EACH		
06	PROVISION OF RING EARTH			
a)	40M NBFL GBT	Per Tower		
07	SUPPLYING OF G.I. NUTS, BOLTS & OTHER MISSING TOWER MATERIALS			
		Per Kg.		
8	CARRIAGE OF TOWER MATERIALS FOR 40M GBT			
a)	Per Tower including loading & unloading Charges.(Lump sum)	Up to 50 Km		
b)	Per Tower including loading & unloading Charges.(Lump sum)	51 Km to 200 Km		
c)	Per Tower including loading & unloading Charges per KM	Above 200 km		
9	SUPPLY & FITTING OF WAVE GUIDE RACK			
a)	Fabrication, supply and fitting of Horizontal wave guide rack as per depl. Specification. (Rate per running meter including fitting)	Per meter		
b)	Fabrication, supply and fitting of vertical support to Horizontal wave guide rack as per depl. Specification. (Rate per running meter including fitting)	Per meter		
10	ONLY FITTING OF WAVE GUIDE RACK			
a)	Fitting of Horizontal wave guide rack	Per meter		
b)	Fitting of vertical support to Horizontal wave guide rack	Per meter		

- N.B:**1)The calculation formula for evaluation will be as per **Clause-21.4 Sec.-II** of the tender documents.
2). **Service tax will be paid extra wherever applicable as per rate in force.**

Place:

Signature of contractor

Date:

Name:

SIGNATURE OF THE TENDERER WITH SEAL

SECTION-VIII
UNDERTAKING & DECLARATION

The tenderer hereby covenants and declares that all the information, Documents, Xerox copies of the Documents/ Certificates enclosed along with the Tender document are correct and if any thing found false and/or incorrect and/or any suppression of fact is detected at any time, tender will be terminated and EMD/SD/Bills pending with company will stand forfeited to BSNL and the contractor will be debarred from participation of any tender of this company in future.

Certify the I/We read and agree with all the terms and conditions, specifications included in the tender documents & offer to execute the work at the rates quoted in the schedule. If I/We fail to enter into the agreement & commence the work in time the EMD/SD as deposited will stand forfeited to the BSNL.

Signature of Tenderer
along with date & Seal

SIGNATURE OF THE TENDERER WITH SEAL

**SECTION-IX
PERFORMANCE SECURITY GUARANTEE (BOND FORM)**

In consideration of the CMD, Bharat Sanchar Nigam Ltd having agreed to exempt
. . . [hereinafter called the "Contractor(s) "] from the demand, under the terms and conditions of an
agreement/Purchaser Order) No. Dated..... made between and
. for for the supply of (hereinafter called the "the said
agreement"), of security deposit for the due fulfillment by the said Contractor (s) of the terms and
conditions contained in the said Agreement, on production of a bank guarantee for
. we, (Name of the Bank) (hereinafter referred to as "the Bank") at the
request of (contractor(s) do hereby undertake to pay to the BSNL an amount not
exceeding against any loss or damage caused to or suffered or would be caused to
or suffered by the BSNL by reason or any breach by the said Contractor(s) of any of the terms or
conditions contained in the said Agreement.

2. We (Name of the Bank) do hereby undertake to pay the amounts due and
payable under this guarantee without any demur, merely on a demand from the BSNL stating that he
amount claimed is due by way of loss or damage caused to or would be caused to or suffered by the
BSNL by reason of breach by the said contractor(s) of any of terms or conditions contained in the said
Agreement or by reason of the contractor (s) failure to perform the said Agreement. Any such demand
made on the bank shall be conclusive as regards the amount due and payable by the Bank under this
guarantee where the decision of the BSNL in these counts shall be final and binding on the bank.
However, our liability under this guarantee shall be restricted to an amount not exceeding

3. We undertake to pay to the BSNL any money so demanded notwithstanding any dispute or
disputes raised by the Contractor(s) / suppliers in any suit or proceeding before any court or tribunal
relating thereto our liability under this present being absolute and unequivocal. The Payment so made by
us under this bond shall be valid discharge of our liability for payment there under and the contractor(s) /
supplier(s) shall have no claim against us for making such payment.

4. We (name of the Bank) further agree that the guarantee herein contained shall remain
in full force and effect during the period that would be taken for the performance of the said agreement and
that it shall continue to be enforceable till all the dues of the BSNL under or by virtue of the said Agreement
have been fully paid and its claims satisfied or discharged or till (office
/BSNL) Certifies that the terms and conditions of the said Agreement have been fully
and properly carried out by the said contractor(s) and accordingly discharge this guarantee. Unless a
demand or claim under this guarantee is made on us in writing or before the expiry of THREE YEARS from
the date hereof, we shall be discharged from all liability under this guarantee thereafter.

5. We (name of the Bank) further agree with the BSNL that the BSNL shall have the
fullest liberty without our consent and without affecting in any manner our obligations hereunder to vary
any of the terms and conditions of the said Agreement or to extend time of performance by the said
contractor(s) from time to time or to postpone for any time or from time to time any of the powers
exercisable by the BSNL against the said contractor(s) and to forbear or enforce any of the terms and
conditions relating to the said agreement and we shall not be relieved from our liability by reason of any
such variation, or extension being granted to the said Contractor(s) or for any forbearance, act or omission
on the part of the BSNL or any indulgence by the BSNL to the said contractor(s) or by any such matter or
thing whatsoever which under the law relating to sureties would, but for this provision, have effect of so
relieving us.

6. This guarantee will not be discharged due to the change in the constitution of the Bank or the
contractor(s) / supplier(s).

7. We (Name of the Bank) Lastly undertake not to revoke this guarantee during its
currency except with the previous consent of the BSNL in writing.

Dated the Date

For

(Indicate the name of the Bank)

SECTION-X

LETTER OF AUTHORISATION FOR ATTENDING BID OPENING

Subject: Authorization for attending Bid opening on (Date) in the tender
of
.....

Following person is hereby authorized to attend the bid opening for the tender mentioned above on behalf
of(Bidder) .

<u>Name</u>	<u>Specimen Signature</u>

Alternate Representative

Signature of Bidder

Or

Officer authorized to sign the Bid

Document on behalf of the Bidder.

- Note : 1. Maximum of one representative will be permitted to attend the Bid opening
2. Permission for entry to the hall where bids are opened may be refused in case authorization as prescribed above is not recovered.

SECTION-XI

BID SECURITY FORM

Whereas(hereinafter called "the Bidder") has submitted its bid dated for the supply of Tender No.
..... KNOW ALL MEN by these Presents that WE OF
having out registered office at (here in after called "the Bank") are bound unto
..... (here in after called the "the Purchase") in the sum of for which payment will and truly to be made of the said Purchase, the Bank binds itself, its successors and assigns by these presents.

THE CONDITIONS of the obligation are:

- 1. If the Bidder withdraws its bid during the period of bid validity specified by the Bidder on the Bid form; or
- 2. If the Bidder, having been notified of the acceptance of its Bid by the Purchaser during the Period of Bid validity.
 - a) Fails, or refuses to execute the Contract, if required, or
 - b) Fails or refuses to furnish performance security, in accordance with the Instructions to Bidders.

We undertake to pay to the Purchaser up to the above amount upon receipt of its first written demand, without the Purchaser having to substantiate its demand, provided that in its demand, the Purchaser will note that the amount claimed by it is owing to the occurrence of one or all of three conditions, specifying the occurred condition or conditions.

This guarantee will remain in force as specified in clauses 12 and 28.2 of section II of the Bid Document up to and including Thirty (30) days after the period of Bid validity, and any demand in respect thereof should reach the Bank not later than the specified date/dates.

Signature of the Bank

Name.....

Signed in capacity of
Name of Witness
Signature of Witness
Address of Witness
Full Address of Branch
STD Code & Telephone No. of Branch
FAX No. Of Branch

SECTION-XII

PROFORMA FOR NO NEAR RELATIVES CERTIFICATE IN BSNL

Certificate to be given by the contractor in respect of no near
Relative (s) in BSNL of the contractor.

I,
S/o.....resident of

.....
hereby certify that none of my near relative(s) as defined in the tender document is/are employed any
where in BSNL as per details given in tender document. In case at any stage, it is found that the
information given by me is false/incorrect, BSNL shall have the absolute right to take any action as
deemed fit, without any prior intimation to me.

Signature of the tenderer with seal

Note: In case of proprietorship firm, certificate will be given by the proprietor, for partnership firm,
certificate will be given by all the partners and in case of Private Ltd. Company, by all the directors
of the company.

SECTION-XIII

INFORMATION ABOUT TENDERERS

(To be filled in and submitted by the bidder)

1. NAME OF THE INDIVIDUAL/FIRM _____

2. PRESENT ADDRESS

3. PERMANENT ADDRESS

Tel No.

Tel No.

- 4. Whether it is sole proprietor/or partnership firm/private limited company.
- 5. Name of the sole proprietor/Name of the partners/Name of the Director(s)
- 6. Name of the person authorized to enter into and execute contract agreement and the Capacity in which he is authorized (in case of partnership/private firm)
- 7. Permanent Income Tax No.
- 8. Whether the firm is having branches at more than one place? If so details
- 9. Number of labours under command that can be simultaneously engaged and the time required for mobilizing that such number that can be mobilized within a period of 15 (fifteen) days from the date of work order.
- 10. Major works employing large labour force/work involving, erection of telecom towers and associated works are undertaken by the firm in the last three consecutive years. Copies of such work orders along with certificate of satisfactory performance to be attached.

Place.....

Signature.....

Date

Name.....

Date

Name.....

Issued to.....

Signature of issuing officer

SECTION-XIV
AGREEMENT

AGREEMENT made on thisbetween the General Manager (CMTS), BSNL, Odisha Telecom Circle, Bhubaneswar for and on behalf of BSNL, (which expression shall unless executed by or repugnant to the context include his successors and assignees) on one part andherein after called the "contractor" (which terms shall include their heirs, executors, successors and assignees) on the other part.

Where as in response to the Tender Notice No.....issued by G.M.(CMTS), BSNL, Odisha Telecom Circle, Bhubaneswar andhas been declared successful tenderer for the work.

Where as this office is desirous of getting executed work of : That the ERECTION OF 40M NBLW GROUND BASE TOWER & IT'S ASSOCIATED WORKS IN ODISHA FOR GSM MOBILE PROJECT includes The contractor has offered to enter into a contract with the BSNL for the said work as per the terms and conditions specified under the CONDITIONS OF CONTRACT in accordance with the CONSTRUCTION SPECIFICATION, at the rates mentioned in the **ANNEXURE-I**.

Now this agreement witnessed and it is hereby agreed and declared and between the parties as follows:

1. That the contract shall remain valid for a period of one year from the date of agreement.
2. That the tender document containing instruction to tenderer CONSTRUCTION SPECIFICATION AND CONDITION OF CONTRACT annexed hereto and such other additional particulars, instruction, drawings as may be found requisite to be given during execution of the contract shall also be deemed to be included in the expression "contract" or "contract document" wherever herein used.
3. That in consideration of the payments to be made to the contractor for the work to be executed by him the contractor hereby conversant with the contract documents duly provide, execute and complete the said works and shall perform all other acts, deeds, matters and things in the contract mentioned or described or which are to be implied there from or may be reasonably necessary for the completion of the said works and at the same time and in the manner and subject to the terms and conditions stipulations mentioned in the contract.
4. That in consideration of the due provisions, executions and completion of the said works, the BSNL hereby agree with the contractor the respective amounts for the work done by the contractor and such other sum(s) as may become payable to the contractor under the provisions of contract.
5. That the CMTS unit, Bhubaneswar is free to distribute the work more than one bidder as per the tender criteria and the L-1 bidder will abide the instructions.
6. That in accordance with the provision of Tender Document this agreement is being executed on deposit of Security Amount and EMD amount as detailed herein for ERECTION OF 40M NBFL AND 60 M TTH GROUND BASE TOWER & IT'S ASSOCIATED WORKS IN ODISHA FOR GSM MOBILE PROJECT

NAME OF WORK	EMD DETAILS	P.S.D.DETAILS
ERECTION OF 40M NBFL GROUND BASE TOWER & IT'S ASSOCIATED WORKS IN ODISHA FOR GSM MOBILE PROJECT		

SIGNED & DELIVERED ON
BEHALF OF CONTRACTOR

SIGNED & DELIVERED
ON BEHALF OF BSNL

ADDRESS OF CONTRACTOR

PRESENT	PERMANENT
---------	-----------

IN PRESENCE OF

- | | |
|----------------|----------------|
| 1. SIGNATURE : | 2. SIGNATURE : |
| NAME : | NAME : |
| ADDRESS : | ADDRESS : |

SIGNATURE OF THE TENDERER WITH SEAL